



SIR ISSAC NEWTON COLLEGE OF ENGINEERING & TECHNOLOGY

(Approved by AICTE and Affiliated to Anna University, Chennai.)

Velankanni Road, Pappakoil, Andhanapet - post, Nagapattinam - 611 102

Office Cell: 73737 65117 | Principal Cell: 73737 65120 | Email: principalsincet@gmail.com

COUNSELLING CODE
3760

DEPARTMENT OF MECHANICAL ENGINEERING

LABORATORY MANUAL ME 8361 / MANUFACTURING TECHNOLOGY LABORATORY - I SEMESTER III / YEAR - II (R-2017)



PREPARED BY,

VEERAPANDIAN K
MECHANICAL ENGINEERING
SINCET

TABLE OF CONTENTS

S. NO.	CONTENTS	PAGE NO
1	Vision & Mission(Institute & Department)	I
2	Programme Education Objective (PEO's) & Programme specific Outcomes(PO's)	I
3	Program Outcomes-PO's	II
3	Syllabus	III
4	Course Outcomes(CO's) & Mapping of CO's, PO's and PSO's	IV
5	List of Experiments	V
6	Contain Beyond the syllabus -Additional Experiments	V
7	Viva Questions	V

Vision of the Institute

To Develop Globally Competitive Human Resource through Virtuous Enlightened Learning.

Mission of the Institute

M1: To Impart Quality Technical Education and Research Orientation Enabling the Technocrats to Fair Well in Global Competition.

M2: To Inculcate Committed Leadership Qualities through Ethical Practices.

M3: To Acquire Skills through Industry Practices and Develop the habit of life-long learning.

Vision of the Department

To produce high quality Mechanical engineers who contributes effectively in the process of building Nation.

Mission of the Department

M1: To Impart Quality Technical Education and Research by Collaborating with Stake holders and Community.

M2: To Adopt the Best Pedagogical Methods to maximize knowledge transfer by providing conducive ambience.

M3: To Create modern lab facilities to understand and implement theoretical concepts in practical Scenarios to match industrial necessities

M4: To inculcate leadership skills, social responsibilities and life-long learning among students.

PROGRAMME EDUCATIONAL OBJECTIVES (PEO's)

PEO1: Have successful career in Mechanical Engineering or in other related discipline.

PEO 2: Contribute towards technological development in the domain of Thermal, Design and Manufacturing.

PEO 3: Practice their profession with good communication, leadership, ethics and social responsibility.

PEO 4: Graduates will adapt to evolving technologies through life-long learning.

PROGRAMME SPECIFIC OUTCOMES (PSO's)

PSO 1: Apply their knowledge in the domain of engineering Design, Manufacturing, thermal and fluid sciences to solve real world mechanical Engineering problems.

PSO 2: Develop and implement new ideas in product design and development using modern CAD/CAM/CAE tools, by ensuring best manufacturing practices.

PROGRAM OUTCOMES (PO's)

Engineering Graduates will be able to:

- 1. Engineering knowledge:** Apply the knowledge of mathematics, science, engineering fundamentals, and an engineering specialization to the solution of complex engineering problems.
- 2. Problem analysis:** Identify, formulate, review research literature, and analyze complex engineering problems reaching substantiated conclusions using first principles of mathematics, natural sciences, and engineering sciences.
- 3. Design/development of solutions:** Design solutions for complex engineering problems and design system components or processes that meet the specified needs with appropriate consideration for the public health and safety, and the cultural, societal, and environmental considerations.
- 4. Conduct investigations of complex problems:** Use research-based knowledge and research methods including design of experiments, analysis and interpretation of data, and synthesis of the information to provide valid conclusions.
- 5. Modern tool usage:** Create, select, and apply appropriate techniques, resources, and modern engineering and IT tools including prediction and modeling to complex engineering activities with an understanding of the limitations.
- 6. The engineer and society:** Apply reasoning informed by the contextual knowledge to assess societal, health, safety, legal and cultural issues and the consequent responsibilities relevant to the professional engineering practice.
- 7. Environment and sustainability:** Understand the impact of the professional engineering solutions in societal and environmental contexts, and demonstrate the knowledge of, and need for sustainable development.
- 8. Ethics:** Apply ethical principles and commit to professional ethics and responsibilities and norms of the engineering practice.
- 9. Individual and team work:** Function effectively as an individual, and as a member or leader in diverse teams, and in multidisciplinary settings.
- 10. Communication:** Communicate effectively on complex engineering activities with the engineering community and with society at large, such as, being able to comprehend and write effective reports and design documentation, make effective presentations, and give and receive clear instructions.
- 11. Project management and finance:** Demonstrate knowledge and understanding of the engineering and management principles and apply these to one's own work, as a member and leader in a team, to manage projects and in multidisciplinary environments.
- 12. Life-long learning:** Recognize the need for, and have the preparation and ability to engage in independent and life-long learning in the broadest context of technological change.

OBJECTIVE:

To Study and practice the various operations that can be performed in lathe, shaper, drilling, milling machines etc. and to equip with the practical knowledge required in the core industries.

LIST OF EXPERIMENTS

Machining and Machining time estimations for:

1. Taper Turning
2. External Thread cutting
3. Internal Thread Cutting
4. Eccentric Turning
5. Knurling
6. Square Head Shaping
7. Hexagonal Head Shaping
8. Fabrication of simple structural shapes using Gas Metal Arc Welding
9. Joining of plates and pipes using Gas Metal Arc Welding/ Arc Welding /Submerged arc welding
10. Preparation of green sand moulds
- 11 Manufacturing of simple sheet metal components using shearing and bending operations.
12. Manufacturing of sheet metal components using metal spinning on a lathe

TOTAL: 60 PERIODS

OUTCOMES:

Upon the completion of this course the students will be able to

C01 Demonstrate the safety precautions exercised in the mechanical workshop.

C02 Make the work piece as per given shape and size using Lathe.

C03 Join two metals using arc welding.

C04 Use sheet metal fabrication tools and make simple tray and funnel.

C05 Use different moulding tools, patterns and prepare sand moulds.

LIST OF EQUIPMENT FOR A BATCH OF 30 STUDENTS

S. NO.	NAME OF THE EQUIPMENT	Qty.
1	Centre Lathes	7 Nos.
2	Horizontal Milling Machine	1No.
3	Vertical Milling Machine	1 No.
4	Shaper	1 No.
5	Arc welding transformer with cables and holders	2 Nos.
6	Oxygen and acetylene gas cylinders, blow pipe and other welding outfit	1 Nos.
7	Moulding table, Moulding equipments	2 Nos.
8	Sheet metal forming tools and equipments	2 Nos.

COURSE OUTCOMES

COURSE CODE	ME 8361	COURSE NAME	MANUFACTURING TECHNOLOGY LABORATORY-I	SEM	3
C01	Perform basic machining operations as per the given size using Lathe machine tool				
C02	Perform Square Head and Hexagonal Head using Shaping /Milling machine tool				
C03	Join two similar metals using varies welding Techniques.				
C04	Prepare sand moulding by using varies patterns and moulding tools.				
C05	Fabricate simple tray and funnel using sheet metal tools.				

CO'S -PO'S / PSO'S MAPPING

CO/ PO	P01	P02	P03	P04	P05	P06	P07	P08	P09	P010	P011	P012	PS01	PS02
C01	3	2	1		1			2	2	2		1	3	3
C02	3	2	1		1			2	2	2		1	3	3
C03	3	2	1		1			2	2	2		1	3	3
C04	3	2	1		1			2	2	2		1	3	3
C05	3	2	2		1			2	2	2		1	3	3

LIST OF EXPERIMENTS:

Ex.No	Name of the Experiment	Hours	Relevance to CO's	PAGE NO
1	Taper Turning Using Compound Rest Method	4	CO1	8
2	External Thread cutting	4	CO1	10
3	Drilling,, Boring and Internal Thread Cutting	4	CO1	12
4	Eccentric Turning	4	CO1	14
5	Knurling	4	CO1	16
6	Square Head Shaping	4	CO2	20
7	Hexagonal Head Shaping	4	CO2	24
8	Double V-Butt Joint	4	CO3	29
9	Lap Joint	4	CO3	31
10	T- Fillet Joint	4	CO3	33
11	Gear Pattern	4	CO4	37
12	Stepped Cone Pulley	4	CO4	39
13	Rectangular Tray	4	CO5	44
14	Funnel	4	CO5	46
15	Metal Spinning	4	CO5	48
CONTENT BEYOND SYLLABUS				
1	Taper Turning by Tail stock set over method	4	CO1	50
2	SLOTTING – KEY WAY	4	CO2	52
3	SHAPER-V SURFACE	4	CO2	54
Viva Questions				56 To 59

GENERAL SAFETY PRECAUTION

1. Always wear uniform, shoes and gloves for safety
2. Never operate any machines until you have been instructed properly
3. Always wear goggles to protect your eyes from flying chips.
4. Never hold the job when the machine runs.
5. Never give heavy cut on longer job
6. Never change the gear and belt when the machine is running
7. Always use the correct size spanner and tool for fitting and removing of tool
8. Never try to clear the chips when the machine is running
9. To prevent accident, clean the spilled oil and grease immediately
10. Always clear the area around the machine and machine tool surface
11. No open toed shoes or sandals are allowed in the shop.
12. Do not wear loose clothing. Cotton clothes are best to wear.
13. Remove all jewelry and tie back long hair.
14. Do not operate any machine equipment unless you have been instructed on its proper use and the safety risks involved with the machining operation.
15. Do not leave any machinery or power tools running and unattended.
16. Clean up metal shavings, oil, etc. from machine tools after use; pick up after yourself and return tools to their proper storage area.
17. Don't run, push or surprise other students. No horse play will be tolerated
18. Always listen carefully to the teacher and follow instructions.
19. Know where the emergency stop buttons are positioned in the workshop. If you see an accident at the other side of the workshop you can use the emergency stop button to turn off all electrical power to machines.
20. Always wear an apron as it will protect your clothes and hold loses clothing such as ties in place.
21. Bags should not be brought into a workshop as people can trip over them.
22. Always be patient, never rush in the workshop.
23. Always use a guard when working on a machine.
24. Keep hands away from moving/rotating machinery.
25. Use hand tools carefully, keeping both hands behind the cutting edge.
26. Report any damage to machines/equipment as this could cause an accident.

I. STUDY OF LATHE MACHINE

Lathe is the machine tool which is used to perform several operations on the work piece. Lathe is useful in making several parts which is further assembled to make new machine. Hence lathe is known as “mother of machines”.

BASIC WORKING PRINCIPLE OF LATHE

In lathe, the work piece is held in the chuck, a work holding device. The cutting tool is mounted in the tool post. The chuck is rotated by means of power. When the chuck rotates, the work piece also rotates. The tool is moved against the rotating work piece by giving small amount of depth of cut. The material is removed in the form of chips. Continuous feed and depth of cut is given until the required dimensions are obtained in the work piece.

TYPES OF LATHE MACHINES

There are different types of lathe machines,

1. Centre lathe
2. Tool room lathe
3. Bench lathe
4. Capstan lathe
5. Turret lathe
6. Automatic lathe

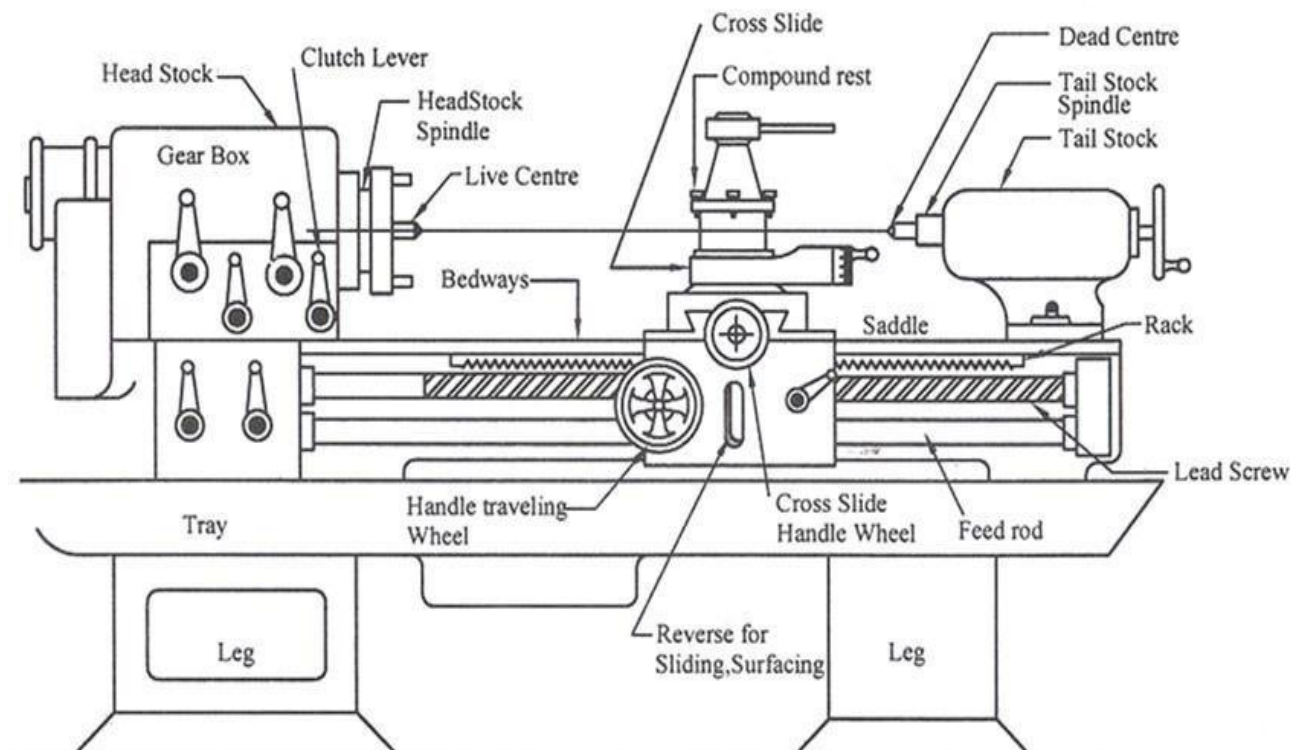

DESCRIPTION OF LATHE

Lathe is a machine tool which has several parts in it. They are

1. Bed

It is the base of the machine. On its left side, the head stock is mounted and on its right it has movable casting known as tailstock. Its legs have holes to bolt down on the ground.

2. Head stock

It consists of spindles, gears and speed changing levers. It is used to transmit the motion to the job. It has two types one is the headstock driven by belt and the other one is the gear driven.

3. Carriage

Carriage is used to carry a tool to bring in contact with the rotating work piece or to with draw from such a contact. It operates on bed ways between the headstock and tail stock.

4. Saddle

It is an 'H' shaped part fitted on the lathe bed. There is a hand wheel to move it on the bed way. Cross slide, compound rest, tool post is fitted on this saddle.

- a) **Cross slide:** It is on the upper slide of saddle in the form of dove tail. A hand wheel is provided to drive the cross slide. It permits the cross wise movement of the tool (i.e.) movement of tool towards or away from the operator
- b) **Compound rest:** It is fitted over the cross slide on a turn table. It permits both parallel and angular movements to cutting tool.
- c) **Tool post:** It is fitted on the top most part of the compound rest. Tool is mounted on this tool post. Cutting tool is fixed in it with the help of screws.

5. Apron

It is the hanging part in front of the carriage. It accommodates the mechanism of hand and power feed to the cutting tool for carrying out different operations.

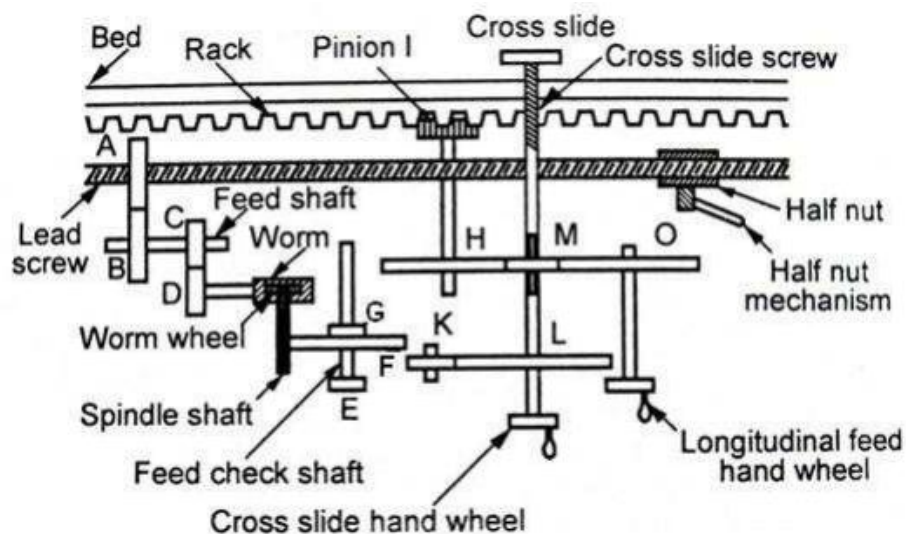

6. Lead screw

It is a long screw with ACME threads. It is used for transmitting power for automatic feed or feed for thread cutting operation.

7. Tail stock

It is located at the right end of the lathe bed and it can be positioned anywhere in the bed. It is used for supporting lengthy jobs and also carries tool to carry out operations such as tapping, drilling, reaming.

WORK HOLDING DEVICES

1. Lathe centers

They are used to support work. It has two categories of centers. Live center is one which is fitted in the headstock spindle. Dead is another one which is fitted in the tail stock.

2. Chuck

It is a device used to hold a job. It is easily fitted on the thread cut on the end of head stock spindle. Various types of chuck are

- Three jaw chuck
- Four jaw chuck
- Magnetic chuck

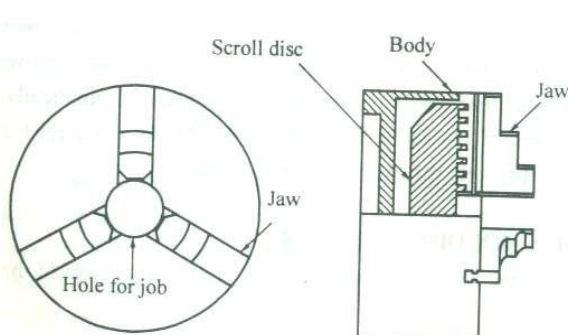

Three Jaw Universal self-centering chuck

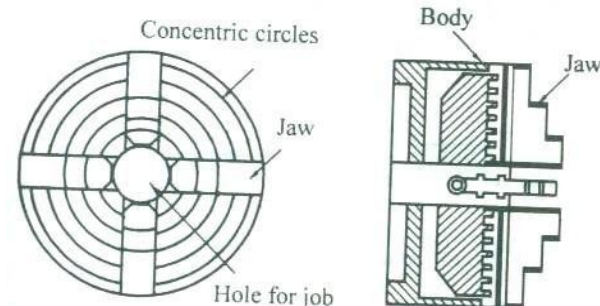

Four Jaw Independent chuck

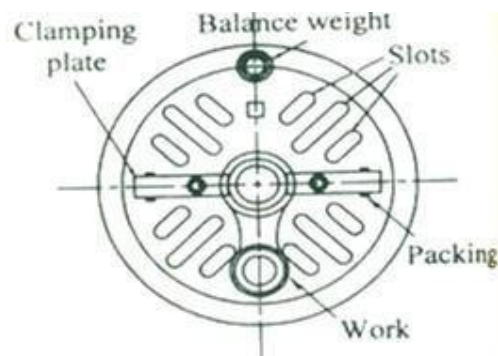

Face Plate

3. Face plate
4. Catch plate
5. Lathe carriers or dog's
6. Steady rest
7. Mandrel
8. Follower rest

CUTTING TOOLS USED

For making a finished job on lathe machine, various types of cutting tools are used. One of them is single point cutting tool which is used to perform several operations on the work piece. Various types of cutting tools are

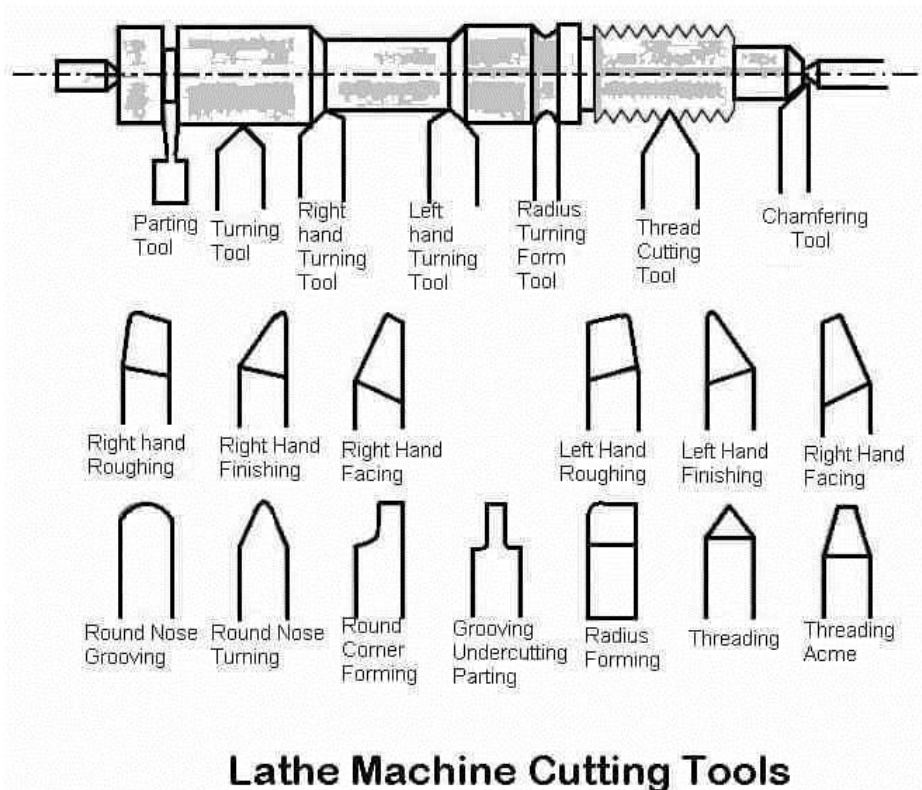

1. Facing Tool

It is used for facing the longitudinal ends of the job. Its shape is like a knife.

2. Rough Turning Tool

It is used to remove excess material from the work piece in quick time. It can be used to give large depth of cut and work at coarse feed.

3. Finishing Tool

It is used for getting smooth finish on the work piece. Its point is a little more round.

4. Radius Tool

Jobs which need round cutting are done with this tool. Its type is

- a) Convex radius tool
- b) concave radius tool

5. Parting Tools

It is used to cut the jobs into two parts. It is also used for grooving.

6. Form Turning Tool

It is used for jobs which require both convex and concave turning.

7. Thread Cutting Tool

It is used for making internal or external threads on the work piece. The tool nose is designed with a definite profile for taking threads.

8. Drill Tool

It is used for making holes of various diameters on the job. Drill bit of various sizes of diameter are available.

9. Boring Tool

It used for enlarging the drill hole.

10. Knurling Tool

Drawing slanting or square projecting lines on the surface of a job is known as knurling. It is used for making better grip on the surface of a job.

LATHE OPERATIONS**1. Facing**

- ❖ It is done for getting fine finish (good surface finish) on the face of the job.
- ❖ Facing tool is set at an angle to the work piece.
- ❖ The tool is fed from the centre of work piece towards the outer surface against the rotating work piece.
- ❖ Depth of cut is low for the facing operation.

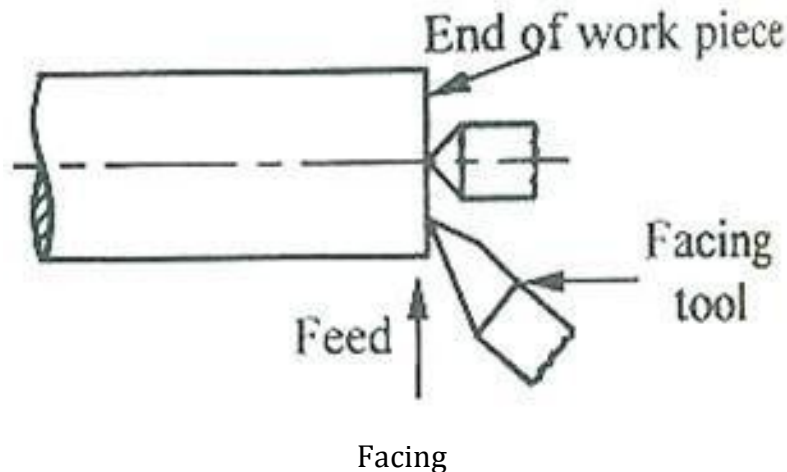

2. PlainTurning

- ❖ It is done for reducing the diameter of the work piece.
- ❖ A cutting tool with 70° setting angle is used for roughing operation.
- ❖ More feed is given for rough turning while less feed is given for finishing.
- ❖ Work piece is held in chuck and tool is set to center height of the work piece.

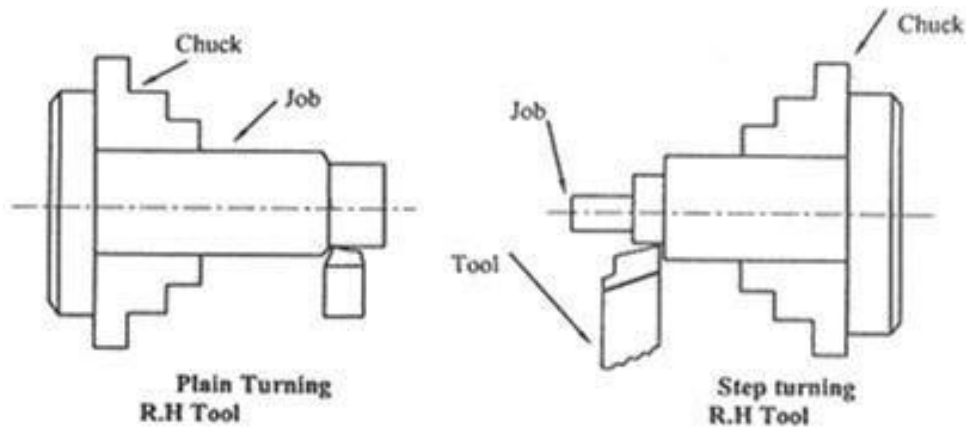

Plain turning

3. Step Turning:

It is similar to the process of turning but in this case different diameter in step of various sizes is taken on the work piece.

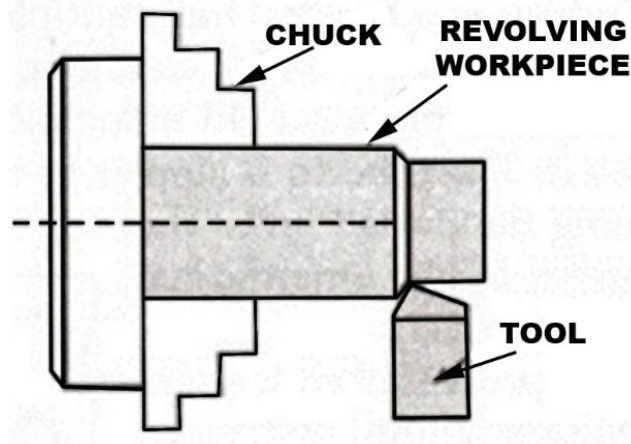

Step Turning

TAPER TURNING USING COMPOUND REST METHOD

EX.NO:

DATE :

AIM:

To produce the component by performing Taper Turning using lathe.

MATERIALS REQUIRED

Mild steel Φ 32 mm X 103 mm long

TOOLS REQUIRED

1. Chuck key
2. Steel Rule
3. Tool Post Spanner
4. Single point Cutting tool
5. Vernier Caliper

FORMULA

The taper angle is calculated using the following formula:

$$\text{Taper angle } (\alpha) = \tan^{-1} \left(\frac{D-d}{2l} \right)$$

Where D = large diameter of taper in mm

d = small diameter of taper in mm

l = length of tapered part in mm

α = angle of taper

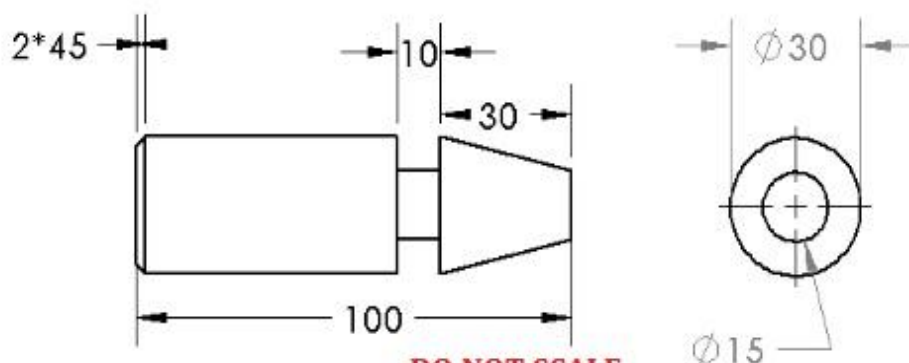
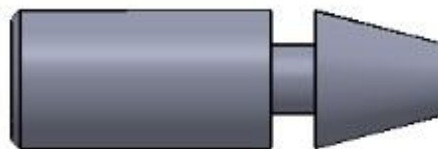
SPECIMEN DRAWING:**TAPER TURNING USING COMPOUND REST**

DO NOT SCALE
ALL DIMENSION ARE IN mm

PROCEDURE

1. The given work piece is held firmly in a lathe chuck.
2. The cutting tool is set in a tool post such that the point of the Cutting tool coincides with the lathe axis.
3. The machine is switched on to revolve the work piece at the selected speed.
4. By giving Cross feed and longitudinal feed to the cutting tool, the facing and turning operations are done respectively.
5. The compound rest is swiveled for the calculated taper angle.
6. By giving angular feed to the cutting tool through the compound slide the taper turning operation is done.
7. The machine is switched off.
8. The work piece is removed from the chuck and all the dimensions are measured and checked.

RESULT: Thus the component is produced as per the given drawing using lathe

EXTERNAL THREAD CUTTING

EX.NO

DATE:

AIM:

To produce the component by performing threads cutting operation using lathe

MATERIAL REQUIRED:

Mild steel Φ 32 mm X 103 mm long

TOOLS REQUIRED:

1. Chuck key
2. Tool post spanner
3. Vernier caliper
4. Steel rule
5. Single point cutting tool
6. V thread cutting tool
7. Pitch gauge
8. Grooving tool
9. Drill chuck with centre drill bit

SPECIMEN DRAWING:

**EXTERNAL
THREAD CUTTING**

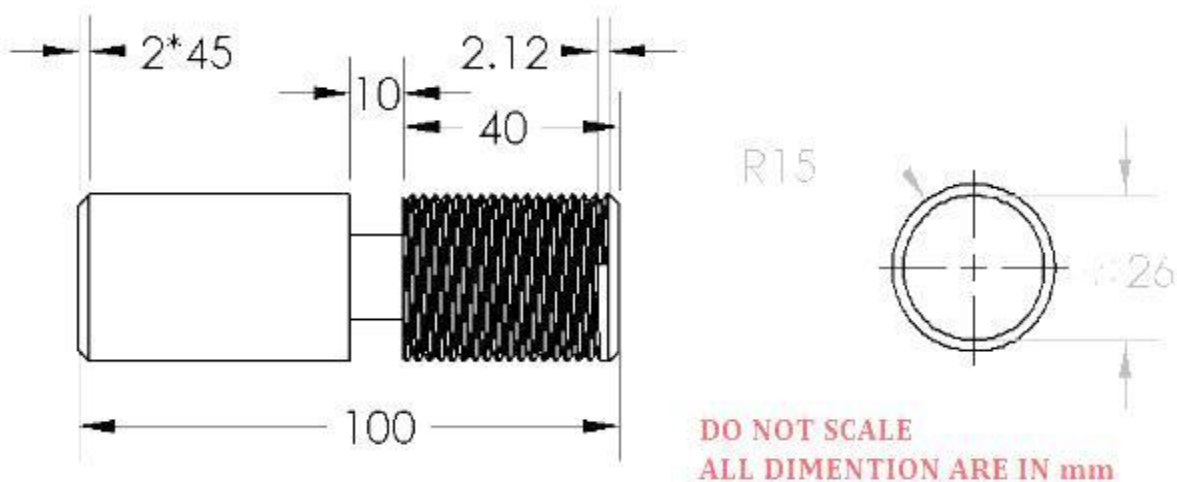
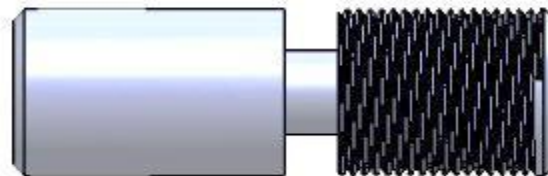

PROCEDURE:

1. Check the size of raw material given and ensure the size.
2. Hold the work pieces in the chuck and tight it properly.
3. Clamp the tool on tool post properly and check the centre of work piece with cutting tool tip.
4. Do the facing operation by giving cross feed to the cross slide and reduce the length.
5. Do the turning operation by giving longitudinal feed to the carriage and reduce the length.
6. Two or three pass can be given for the turning operation.
7. Remove the work piece and hold in chuck on the other side and do the turning operation for the remaining work piece.
8. Engage the back gear mechanism to reduce the speed of the work piece.
9. Check the pitch required, calculate the tumbler gear, and engage it with head stock.
10. Move the carriage towards tail stock and make a mark on the dial.
11. Give small depth of cut and engage the half nut so that the carriage will move automatically towards head stock and cut the v-thread on the work piece.
12. After reaching the required length of thread, release the tool by rotating cross slide in opposite to the depth of cut by counting the number of rotation.
13. Move the carriage towards tail stock, give depth of cut and engage the half nut.
14. Repeat the procedure to produce complete form of v-thread. After finishing remove the work piece from the chuck.

RESULT: Thus the component is produced as per the given drawing using lathe.

DRILLING, BORING AND INTERNAL THREAD CUTTING

EX.NO

DATE:

AIM:

To produce the component by performing drilling, boring and thread cutting using lathe

MATERIAL REQUIRED:

Cast iron Φ 50 mm X 20 mm long

TOOLS REQUIRED:

1. Chuck key
2. Tool post spanner
3. Vernier caliper & Steel rule
4. Single point cutting tool & Boring tool
5. Drill chuck with drill bits
6. Internal thread cutting tool

SPECIMEN DRAWING:

DRILLING, BORING AND INTERNAL THREADING

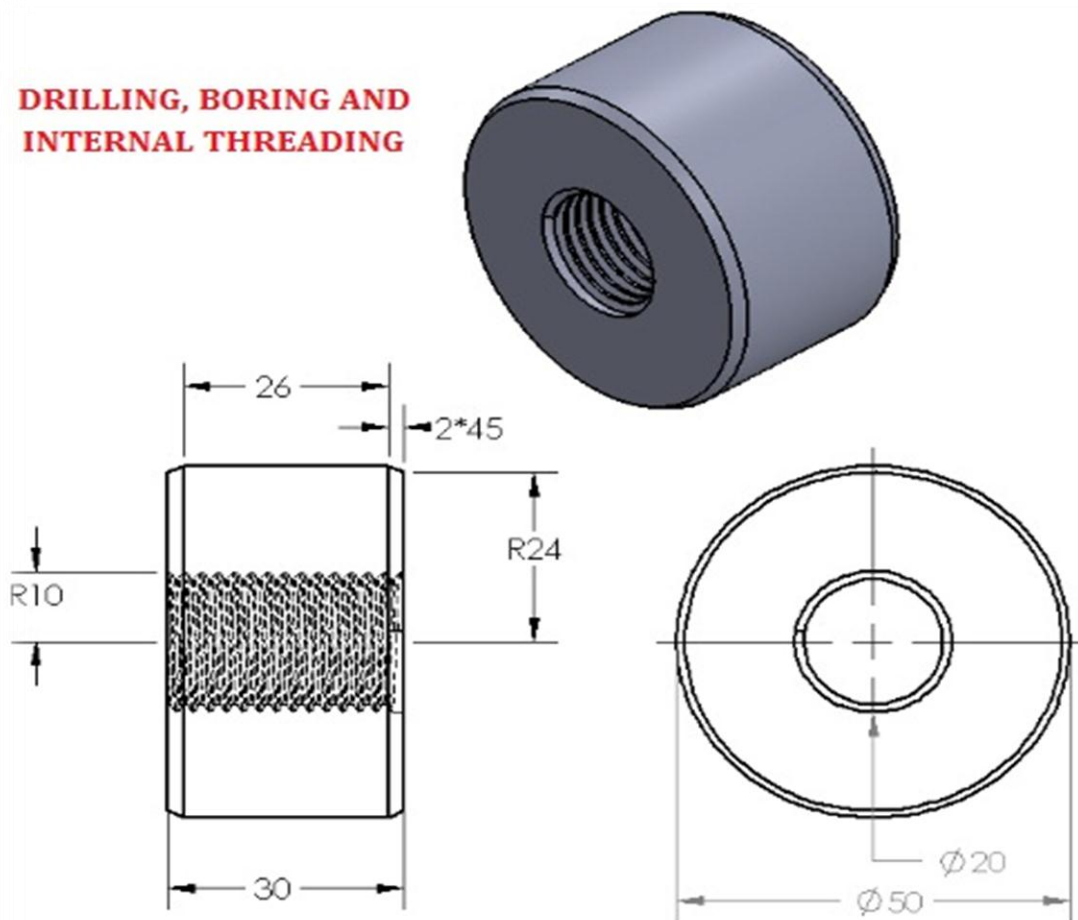

**DO NOT SCALE
ALL DIMENSION ARE IN mm**

PROCEDURE:

1. Check the size of raw material given and ensure the size.
2. Hold the work piece in the chuck and tight it properly.
3. Clamp the tool on tool post properly and check the Centre of work piece with cutting tool tip.
4. Do the facing operation by giving cross feed to the cross slide and reduce the length.
5. Hold the drill bit on the tail stock and unclamp the tail stock, then move it towards the head stock and ensure the Centre coincidence with work piece Centre.
6. Start the motor and give depth of cut to the drill bit by rotating the tail stock wheel and make complete hole.
7. Clamp the boring tool on the tool post to perform the boring operation.
8. Clamp the internal thread tool on the tool post to perform internal threading operation,
9. Engage the back gear mechanism to reduce the speed of the work piece.
10. Check the pitch required, calculate the tumbler gear and engage it with head stock.
11. Move the carriage towards tailstock and make marking on the dial.
12. Give small depth of cut and engage the half nut so that the carriage will move automatically towards headstock and cut the v thread on the work piece.
13. Release the tool by rotating cross slide in opposite to the depth of cut by counting number of rotation after reaching the required length of thread.
14. Move the carriage toward the tail stock and give depth of cut and engage the half nut.
15. Repeat the procedure to produce complete form of v thread. After finishing remove the work piece from the chuck.

RESULT: Thus the component is produced as per the given drawing using lathe

ECCENTRIC TURNING

EX.NO

DATE:

AIM:

To turn a given work piece eccentrically in a lathe machine as per the given dimensions

MATERIAL REQUIRED:

Mild steel Φ 32 mm X 62 mm long

TOOLS REQUIRED:

1. Steel rule
2. Dot punch
3. Ball pen hammer
4. Single point cutting tool
5. Surface gauge
6. Drill bit
7. Drill chuck
8. Boring tool

SPECIMEN DRAWING:



ECCENTRIC TURNING

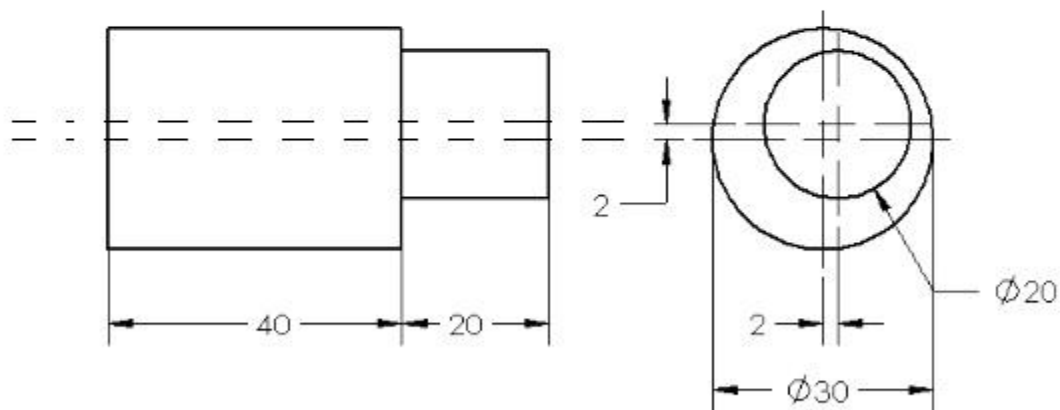

DO NOT SCALE
ALL DIMENSION ARE IN mm

PROCEDURE:

1. Check the size of raw material given and ensure the size.
2. The work piece is fixed in the four jaw chuck using surface gauge.
3. The cutting tool is fixed in the tool post to the lathe axis.
4. Facing operation has been done on both sides of given work pieces.
5. Marking and punching is to be done on the given work pieces as per the dimension.
6. Then the work piece is fixed in the chuck such that the offset point coincides with spindle axis.
7. Using the turning tool, turning operation has been performed.
8. The same procedure is also carried out to the other side of the work piece for the given offset distance.
9. Thus the eccentric turning would be finished.

RESULT: Thus the work piece is turned eccentrically as per the given dimensions.

KNURLING

EX.NO:

DATE

AIM:

To machine a work piece by facing, plain turning and knurling operation using a lathe.

MATERIALS REQUIRED

Mild steel Φ 32 mm X 103 mm long

TOOLS REQUIRED

1. Knurling Tool
2. Chuck Key
3. Steel Rule
4. Tool Post Spanner
5. Single point Cutting tool
6. Vernier Caliper

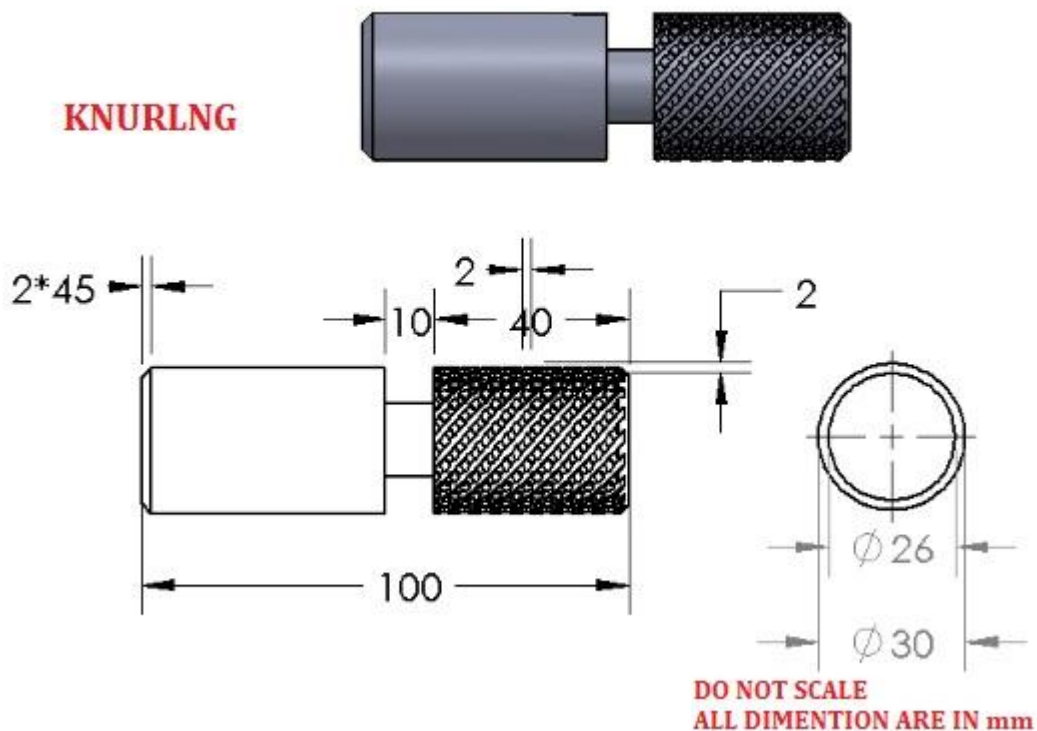
SPECIMEN DRAWING:

PROCEDURE

1. The given work piece is held firmly in a lathe chuck.
2. The cutting tool is set in a tool post such that the point of the Cutting tool coincides with the lathe axis.
3. The machine is switched on to revolve the work piece at the selected speed.
4. By giving Cross feed and longitudinal feed to the cutting tool, the facing and turning operations are done respectively.
5. The speed of the work piece is reduced.
6. The knurling operation is done using knurling tool.
7. The machine is switched off.
8. The work piece is removed from the chuck and all the dimensions are measured and checked.

RESULT: Thus the component is produced as per the given drawing using lathe

II. STUDY OF SHAPER MACHINE

INTRODUCTION:

Shaper is a versatile machine which is primarily intended for producing flat surfaces. These surfaces may be horizontal, vertical or inclined. This machine involves the use of a single point tool held in a properly designed tool box mounted on a reciprocating ram. It is almost an indispensable machine in tool rooms, die making shops and general repair shops, where only a very few job of identical shapes are produced. If properly handled, it can be safely adopted for producing and irregular surfaces also.

The shaper is a machine tool used primarily for:

1. Producing a flat or plane surface which may be in a horizontal, a vertical or an angular plane.
2. Making slots, grooves and keyways
3. Producing contour of concave/convex or a combination of these.

WORKING PRINCIPLE OF A SHAPER:

The job is rigidly fixed on the machine table. The single point cutting tool held properly in the tool post is mounted on a reciprocating ram. The reciprocating motion of the ram is obtained by a quick return motion mechanism. As the ram reciprocates, the tool cuts the material during its forward stroke. During return, there is no cutting action and this stroke is called the idle stroke. The forward and return strokes constitute one operating cycle of the shaper.

In case of shaper, the job is rigidly held in a suitable device like a vice or clamped directly on the machine table. The tool is held in the tool post mounted on the ram of the machine. This ram reciprocates to and fro and is doing so, makes the tool to cut the material in the forward stroke. No cutting of material takes place during the return stroke of the ram. Hence, it is termed as „Idle“ stroke. However, in case of a draw-cut shaper, the cutting takes place in the return stroke and the forward stroke in an idle stroke. The job is given an indexed feed (equal amount after each cut) in a direction normal to the line of action of the cutting tool.

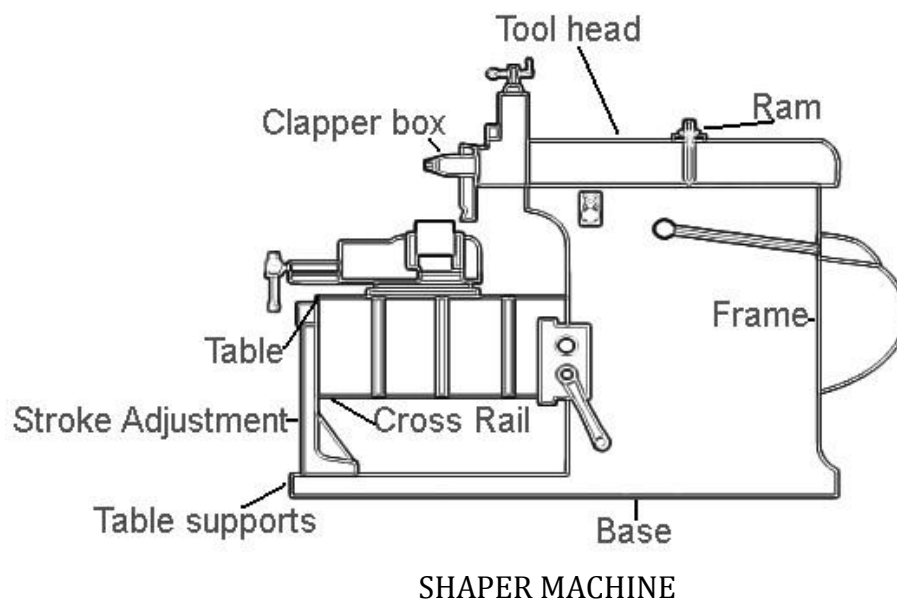

PARTS OF A SHAPER:

➤ Base

It is rigid and heavy cast iron body to resist vibration and takes up high Compressive load. It supports all other parts of the machine, which are mounted over it. The base may be rigidly bolted to the floor of the shop or on the bench according to the size of the machine.

➤ Column

The column is a box shaped casting mounted upon the base. It houses the ram-driving mechanism. Two accurately machined guide ways are provided on the top of the column on which the ram reciprocates.

➤ Cross rail

Cross rail of shaper has two parallel guide ways on its top in the vertical plane that is perpendicular to the rail axis. It is mounted on the front vertical guide ways of the column. It consists mechanism for raising and lowering the table to accommodate different sizes of jobs by rotating an elevating screw which causes the cross rail to slide up and down on the vertical face of the column.

➤ Saddle

The saddle is located on the cross rail and holds the table on its top. Crosswise movement of the saddle by rotation the cross feed screw by hand or power causes the table to move sideways.

➤ Table

The table is a box like casting having T -slots both on the top and sides for clamping the work. It is bolted to the saddle and receives crosswise and vertical movements from the saddle and cross rail.

➤ Ram

It is the reciprocating part of the shaper, which reciprocates on the guide ways provided above the column. Ram is connected to the reciprocating mechanism contained within the column.

CUTTING TOOLS USED IN SHAPER:

The cutting tools for shaper are generally made up of H.S.S or with braze tips. Due the interrupted cuts, tungsten carbide tools are not preferred for shaping work. These tools are made sturdy with fairly generous size for shank and tip. Various types of tools useful for shaping are show in Fig.

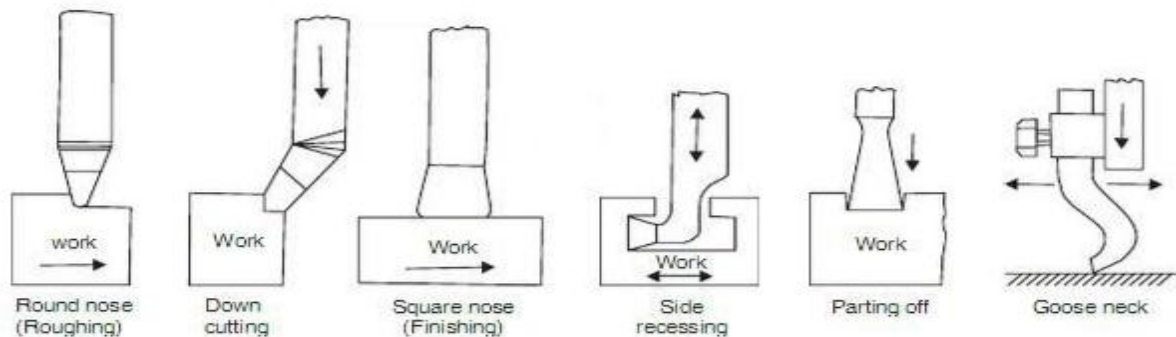

CUTTING TOOLS

SQUARE HEAD SHAPING

EX.NO:

DATE :

AIM:

To make round work piece to square by using shaper.

MATERIALS REQUIRED

Cast iron Φ 50 mm X 15 mm long

TOOLS REQUIRED

1. Steel rule
2. Dot punch
3. Hammer
4. Vernier height gauge
5. T-square
6. Scriber
7. Single point cutting tool
8. Tool holder.

SPECIMEN DRAWING:

SQUARE HEAD SHAPING

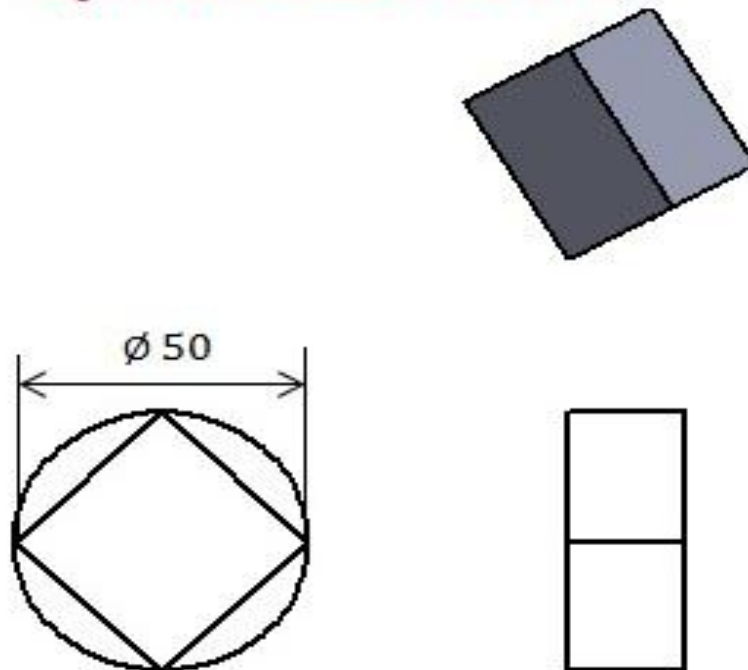

DO NOT SCALE
ALL DIMENSION ARE IN mm

PROCEDURE:

1. Check the size of raw material given and ensure the size.
2. The work piece is fixed in the three-jaw chuck.
3. The cutting tool is fixed in the tool post to the lathe axis.
4. Facing operation has been done on both sides of given work pieces.
5. Chalk is applied uniformly on the face of the work piece.
6. Marking and punching is to be done on the given work pieces as per the dimension.
7. The cutting tool is fixed in the tool holder in shaper machine.
8. The work piece is fixed in the machine vice, then switch on the machine.
9. At the end of each stroke give the feed to the work piece.
10. Shaping operation has been done on four sides in the work piece till the round work piece is turned into square shaped as per the given dimension.

RESULT: Thus the round work piece is machined to square work piece by shaper machine.

III. STUDY OF MILLING MACHINE

INTRODUCTION:

Milling is the machining process of using rotary cutters to remove material from a work piece advancing (or feeding) in a direction at an angle with the axis of the tool. Milling is a cutting process that uses a milling cutter to remove material from the surface of a work piece. The milling cutter is a rotary cutting tool, often with multiple cutting points.

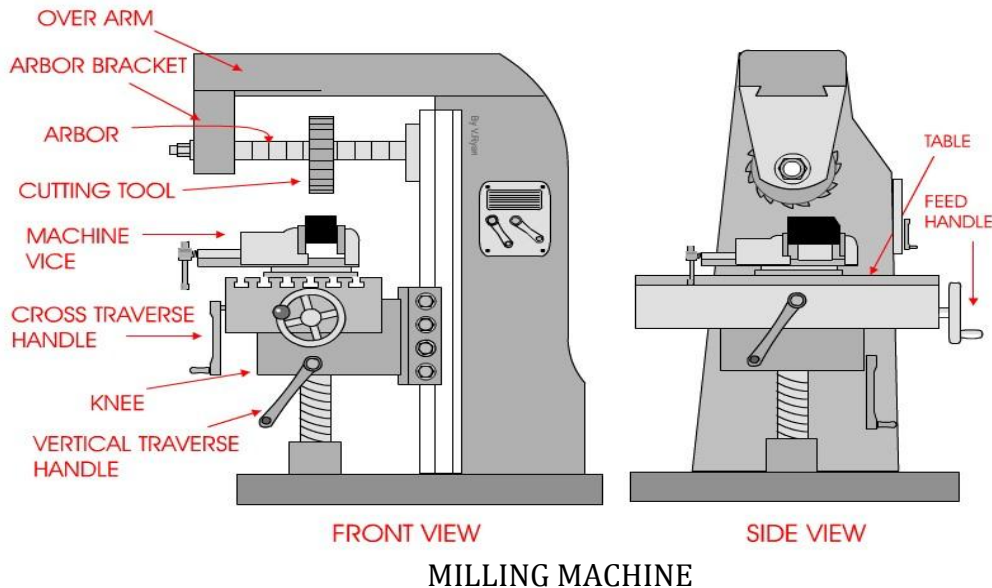

Two major classes of milling process:

1. In **face milling**, the cutting action occurs primarily at the end corners of the milling cutter. Face milling is used to cut flat surfaces (faces) into the work piece, or to cut flat-bottomed cavities.
2. In **peripheral milling**, the cutting action occurs primarily along the circumference of the cutter.

Milling Machine Parts and their Function:

1. BASE:

It is a heavy casting provided at the bottom of the machine. It is accurately machined on both the top and bottom surfaces. It actually acts as a load bearing member for all other parts of the machine. Also it carries the screw jack which supports and moves the knee. In addition to this it also serves as reservoir for the coolant.

2. COLUMN:

It is a very prominent part of the milling machine and is produced with enough care. On the front face of the column are made the vertical parallel ways in which the knee slides up and down. It carries the enclosed motor drive. Top of the column carries dovetail horizontal ways for the over arm.

3. KNEE:

It is a rigid casting, which is capable of sliding up and down along the vertical ways on the front face of the column. This enables the adjustment of the table height. The adjustment is provided by operating the elevating jack, provided below the knee, by means of hand wheel or application of power feed. For efficient operation of the machine, rigidity of the knee and accuracy of its ways play an important role.

4. SADDLE:

It is the intermediate part between the knee and the table and acts as a support for the latter. It can be adjusted crosswise, along the ways provided on the top of the knee, to provide cross feed to the table. As its top, it carries horizontal ways, along which moves the table during longitudinal traverse.

5. TABLE:

It acts as a support for the work. It is made of cast iron, with its top surface accurately machined. Its top carries longitudinal cross T-slots to accommodate the clamping bolts for fixing the work or securing the fixtures. Also, the cutting fluid, after it is used, drains back to the reservoir through these slots and then the pipe fitted for this purpose. Longitudinal feed is provided to it by means of hand wheel fitted on one side of the feed screw.

6. OVERARM:

It is the heavy support provided on the top of both plain and universal milling machine. It can slide horizontally, along the ways provided on the top of the column, and adjusted to a desired position in order to provide support to the projecting arbor.

Milling processes

The various milling processes may be grouped under two headings:

1. Peripheral milling
2. Face milling

1. Peripheral milling: The machining is performed by the cutting edges on the periphery of the milling cutter. It is classified under two headings

- a. Up milling
- b. Down milling

➤ **Up milling:** In this method, the work piece mounted on the table is fed against the direction of rotation of the milling cutter. The cutting force is minimum during the beginning of the cut and maximum at the end of cut. The thickness of chip is more at the end of the cut. As the cutting force is directed upwards, it tends to lift the work piece from the fixtures.

➤ **Down milling:** The work piece mounted on the table is moved in the same direction as that of the rotation of the milling cutter. The cutting force is maximum at the beginning and minimum at the end of cut. The chip thickness is more at the beginning of the cut.

3. Face milling

Face milling is the milling of surfaces that are perpendicular to the cutter axis. Face milling produces flat surfaces and machines work to the required length. In face milling, the feed can be either horizontal or vertical. In face milling, the teeth on the periphery of the cutter do practically all of the cutting. However, when the cutter is properly ground, the face teeth actually remove a small amount of stock which is left as a result of the springing of the work piece or cutter, thereby producing a finer finish.

HEXAGONAL HEAD SHAPING

EX.NO:

DATE :

AIM:

To make a round work piece to hexagonal shape by using milling.

MATERIALS REQUIRED

Cast iron Φ 50 mm X 15 mm long

TOOLS REQUIRED

1. Steel rule
2. Dot punch
3. Hammer
4. Verneir height gauge
5. T-square
6. Scriber
7. Surface plate
8. Single point cutting tool
9. Tool holder.

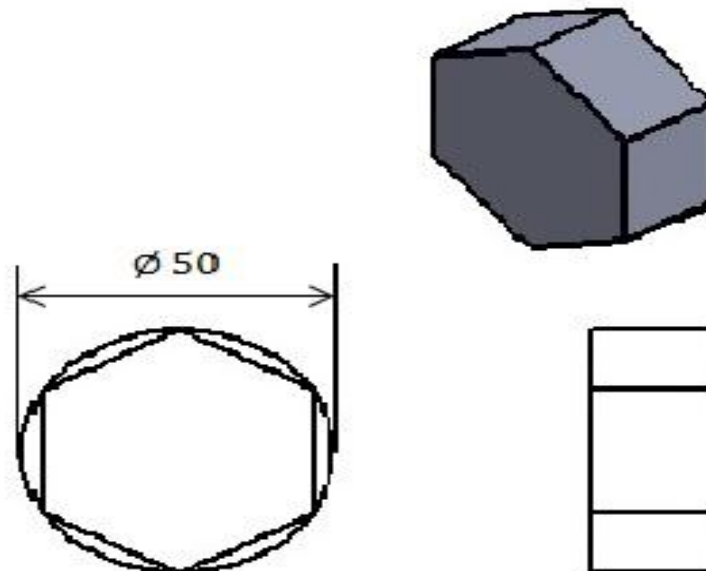
SPECIMEN DRAWING:**HEXAGONAL HEAD SHAPING**

DO NOT SCALE
ALL DIMENTION ARE IN mm

PROCEDURE:

1. Check the size of raw material given and ensure the size.
2. The work piece is fixed in the three jaw chuck.
3. The cutting tool is fixed in the tool post to the lathe axis.
4. Facing operation has been done on both sides of given work pieces.
5. Chalk is applied uniformly on the face of the work piece.
6. Marking and punching is to be done on the given work pieces as per the dimension.
7. The end mill cutter is mounted in the spindle
8. The work piece is fixed in the machine vice, then switch on the machine.
9. The spindle is switched on and the material is removed on one face.
10. Similarly by changing the face, the other sides of the work piece is machined.
11. The job is removed from the machine vice and checked for dimensions using Vernier.
12. Shaping operation has been done on six sides in the work piece till the round work piece is turned into hexagonal shaped as per the given dimension.

RESULT: Thus the round work piece is machined to hexagonal shape by milling machine.

IV. WELDING

INTRODUCTION:

Welding is a metal joining process wherein localized coalescence is produced either by heating the metal to a suitable temperature, with or without the use of filler metal, with or without application of pressure. The filler material has similar compositional melting point temperature as that of the base metal. It is used to fill gap between the join surfaces

SAFETY EQUIPMENTS AND TOOLS:

1 Welding goggles:

Goggles with glasses are used to protect the eyes of the eyes of the welder from the light sparks produced during welding.

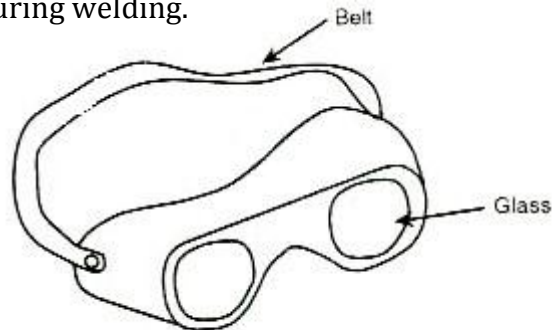

2 Face shield:

A face shield is also used to protect the eyes of the welder from the light sparks produced during welding. It is normally held in hand

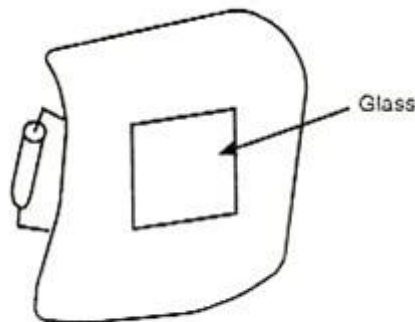

3 Hand gloves:

It is used to protect the hands of the welder from the effect of ultra violet rays, infra red rays, heat and sparks.

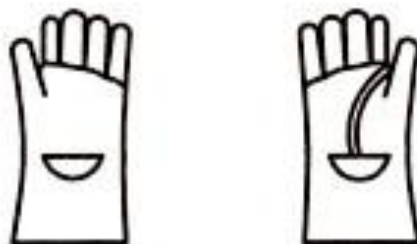

4 Chipping Hammer:

A chipping hammer is used to remove slugs which from during welding.

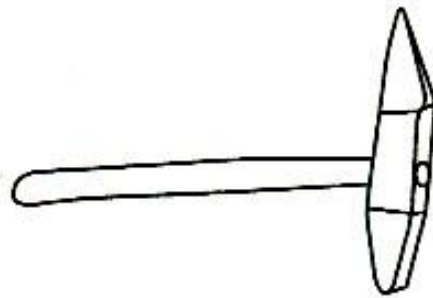
**5 Ground Clamp:**

It is connected to the end of the ground cable. It is normally clamped to the welding table or the job itself to complete the electric circuit.

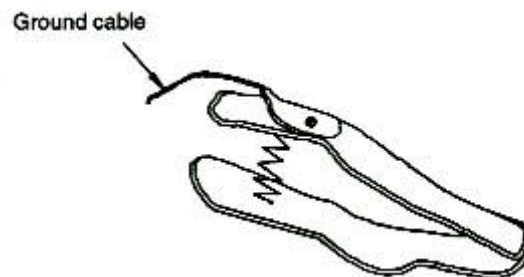
**6 Wire brush:**

The wire brush is used to clean the surface to be welded

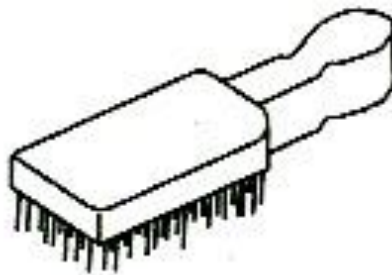
**Types of flames:**

1. Neutral flame (oxygen, acetylene in equal proportions)
2. Oxidizing flame (excess of oxygen)
3. Reducing flame (excess of acetylene)

TYPES OF WELDING:

The two types of welding most prevalently in use are

- a. Arc welding
- b. Gas Arc welding

a. Arc welding:

Electric arc welding is widely used to join metal plates using a filler rod. The filler rod (welding rod) melts on the electric arc produced and welds the metal plates.

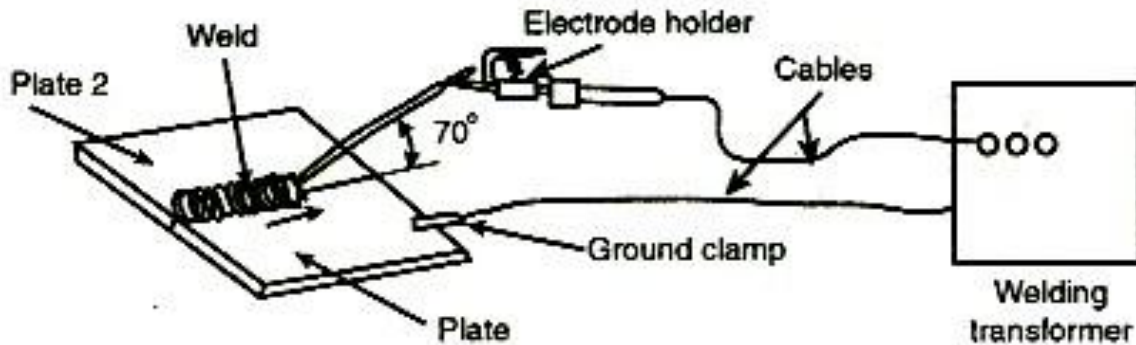
**b. Gas welding:**

Gas welding is a process in which the required heat to melt the surfaces is supplied by a high temperature flame obtained by a mixture of two gases. Usually the mixture of oxygen and acetylene is used for welding purpose. The filler rod and parent metal plates are melted by the heat of the flame produced using oxygen and acetylene gas mixture. Gas welding is also widely used to join metal plates.

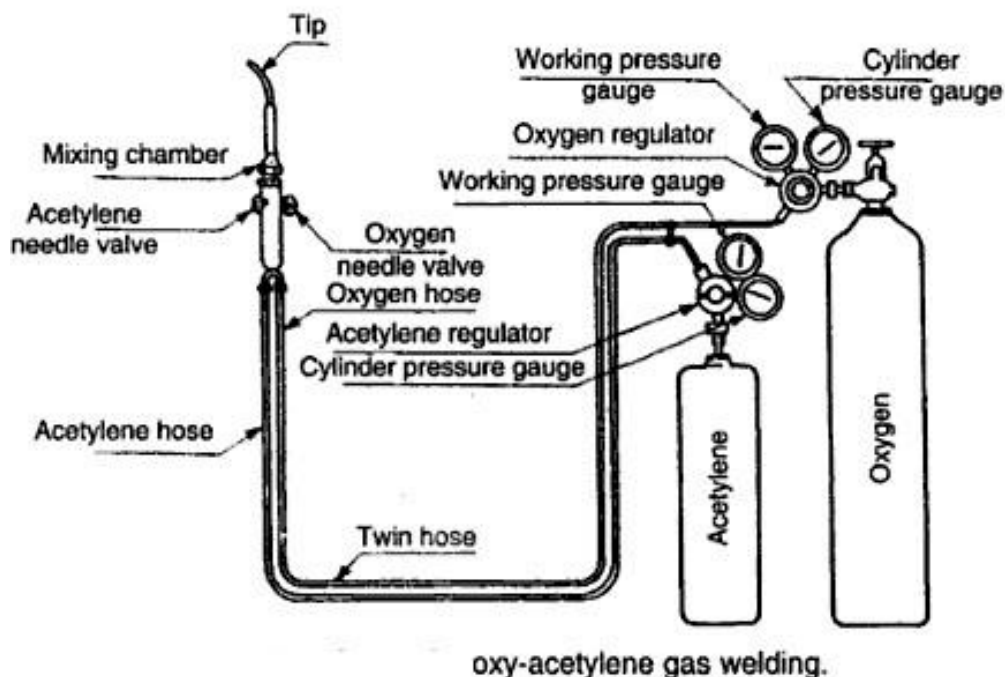

DOUBLE V-BUTT JOINT

EX.NO:

DATE :

AIM:

To make a Double V-Butt joint using arc welding on the given work pieces.

MATERIALS REQUIRED

Mild steel plate of size 100 x 50 x 6mm - 2 Nos.

TOOLS REQUIRED

1. Power supply (AC or DC)
2. Welding Torch
3. Electrodes
4. Tongs
5. Chipping hammer
6. Wire brush
7. Gloves
8. Apron
9. Shield or Safety goggles
10. Earthing clamps

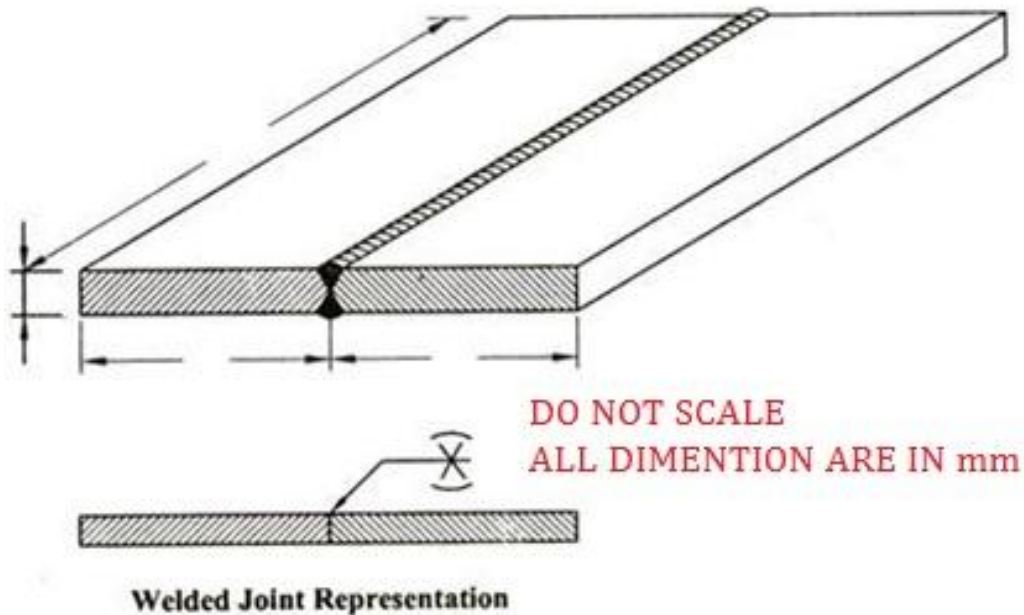
SPECIMEN DRAWING:

SEQUENCE OF OPERATIONS:

1. Edge preparation (Removal of rust, scale etc.,)
2. Tacking
3. Welding
4. Cooling
5. Chipping
6. Cleaning

PROCEDURE:

1. First of all, the work pieces must be thoroughly cleaned to remove rust, scale and other foreign materials.
2. Then the given work pieces are placed on the table in such a way that two work pieces are brought close to each other so that it forms a '**V-Shape**' bough side when the plates butt each other.
3. Appropriate power supply should be given to the electrode and work pieces.
4. Now the welding current output may be existed.
5. When current is passed, arc is produced between the electrode and work pieces.
6. Now set the two work pieces in correct position and maintain the gap 3mm and drack at both ends of the work pieces as shown in the figure.
7. Then the welding is carried out throughout the length.
8. As soon as the welding process is finished, switched off the current supply and allow the work piece to cool.
9. Slags are removed by chipping process with the help of chipping hammer.
10. Finally using wire brush, welded portions are cleaned.

RESULT: Thus the desired Double V-Butt joint is obtained using arc welding.

LAP JOINT

EX.NO:

DATE :

AIM:

To make a lap joint using arc welding on the given work pieces..

MATERIALS REQUIRED

Mild steel plate of size 100 x 50 x 6mm - 2 Nos.

TOOLS REQUIRED

1. Power supply (AC or DC)
2. Welding Torch
3. Electrodes
4. Tongs
5. Chipping hammer
6. Wire brush
7. Gloves
8. Apron
9. Shield
10. Safety goggles
11. Earthing clamps

SPECIMEN DRAWING:

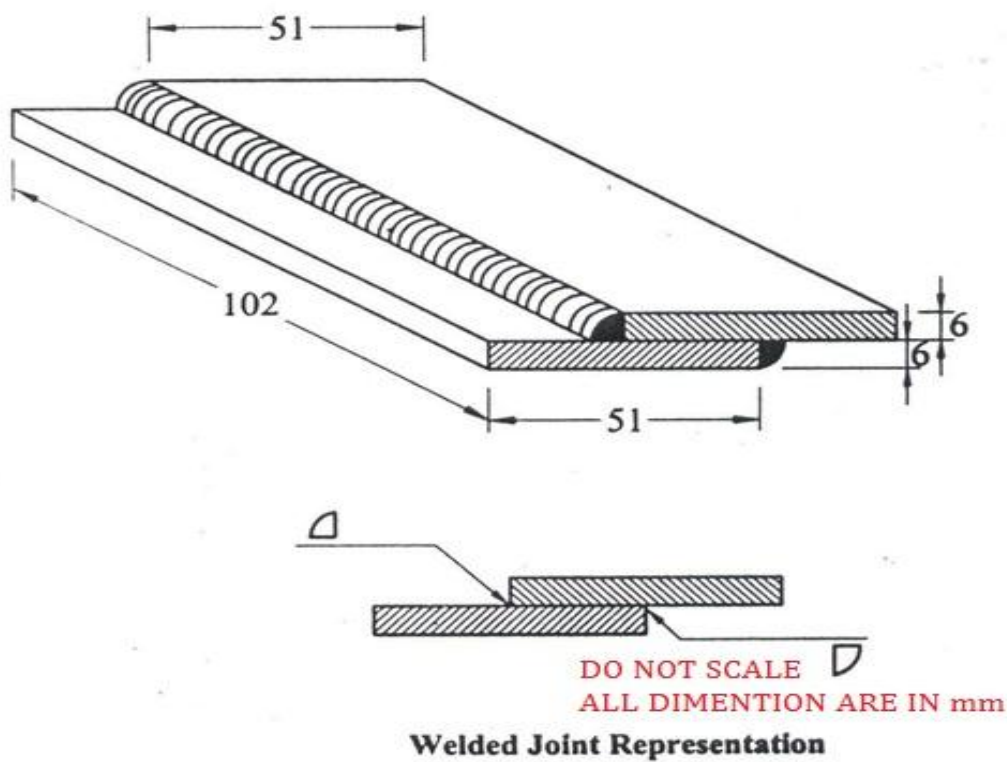

SEQUENCE OF OPERATIONS:

1. Edge preparation (Removal of rust, scale etc.,)
2. Tacking
3. Welding
4. Cooling
5. Chipping
6. Cleaning

PROCEDURE:

1. First of all, the work pieces must be thoroughly cleaned to remove rust, scale and other foreign materials.
2. Then the given work pieces are placed on the table in such a way that two work pieces are overlapped one over another as shown in fig.
3. Appropriate power supply should be given to the electrode and work pieces.
4. Now the welding current output may be existed.
5. When current is passed, arc is produced between the electrode and work pieces.
6. Set the two work pieces in correct position like lap joint and tack at both ends of the work pieces as shown in the figure.
7. Then the welding is carried out throughout the length of the work piece.
8. As soon as the welding process is finished, switch off the current supply and allow the work piece to cool.
9. Slags are removed by chipping process with the help of chipping hammer.
10. Finally using wire brush, welded portions are cleaned.

RESULT: Thus the desired lap joint is obtained using arc welding.

T-FILLET JOINT

EX.NO:

DATE :

AIM:

To make a T-Fillet joint using arc welding on the given work pieces..

MATERIALS REQUIRED

Mild steel plate of size 100 x 50 x 6mm - 2 Nos.

TOOLS REQUIRED

1. Power supply (AC or DC)
2. Welding Torch
3. Electrodes
4. Tongs
5. Chipping hammer
6. Wire brush
7. Gloves
8. Apron
9. Shield
10. Safety goggles
11. Earthing clamps

SPECIMEN DRAWING:

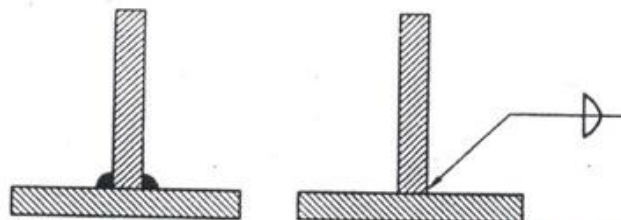
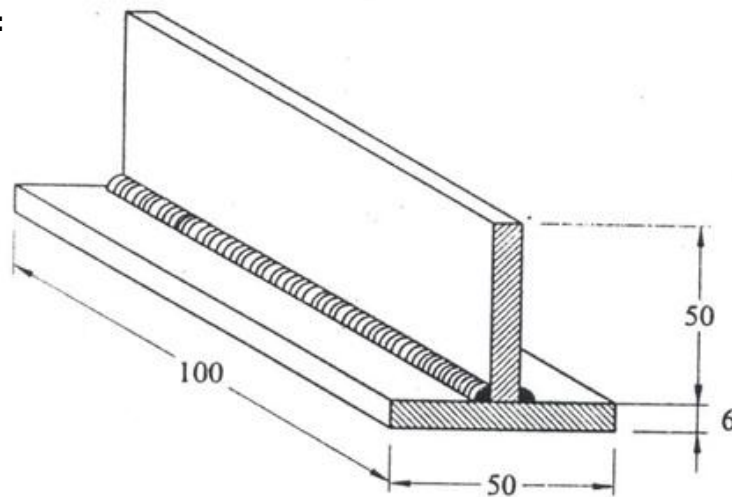

Welded Joint Representation

DO NOT SCALE
ALL DIMENTION ARE IN mm

SEQUENCE OF OPERATIONS:

1. Edge preparation (Removal of rust, scale etc.,)
2. Tacking
3. Welding
4. Cooling
5. Chipping
6. Cleaning

PROCEDURE:

1. First of all, the work pieces must be thoroughly cleaned to remove rust, scale and other foreign materials.
2. Then the given work pieces are placed on the table in such a way that two work pieces are brought close to each other so that it forms a 'T' shape as shown in the fig.
3. Appropriate power supply should be given to the electrode and work pieces.
4. Now the welding current output may be existed.
5. When current is passed, arc is produced between the electrode and work pieces.
6. Set the two work pieces in correct position like T-Fillet joint and tack at both ends of the work pieces as shown in the figure.
7. The joint is placed on a welding table in a flat position by keeping the tack side down.
8. Then the welding is carried out throughout the length.
9. As soon as the welding process is finished, switched off the current supply and allow the work piece to cool.
10. Slags are removed by chipping process with the help of chipping hammer.
11. Finally using wire brush, welded portions are cleaned.

RESULT: Thus the desired T-Fillet joint is obtained using arc welding.

V. FOUNDRY

INTRODUCTION:

Producing components by casting has been since the earliest day of civilization. Lot of shape and sizes can be prepared in a casting process. To make the casting of components, a cavity of desired shape made in moulding sand or other material. The process of moulding consists of all operations done to make a mould.

Pattern: Pattern is the model used to get required casting. It is used to produce to mould cavity in sand.

Foundry: The place where moulding and castings are done is known as foundry.

Moulding sand or Green sand: It is mixture of sand and additives such as water, bentonite, inoculant, sodium silicate etc., used to create mould cavity.

Components required for moulding

The following components are essential for producing mould, Moulding Sand (Green sand), Moulding Boxes, Pattern, Moulding tools.

I. Moulding Sand

It is a special type of sand used for making mould. Moulding sand has three constitues. They are Sand, Binder, Additive.

Properties of moulding sand

A good moulding sand must have the following properties.

- Porosity or permeability
- Plasticity
- Adhesiveness
- Cohesiveness
- Refractoriness

II. Moulding Boxes

Moulding box is also called moulding flask. It is a frame or box of wood or metal. Wood is cheaper boxes made quickly. Wood wears out quickly. It is destroyed by contact with hot metal. Metal boxes in steel, cast iron and aluminum alloys are used in mass production. Moulding boxes are used for making sand moulds. Moulding flasks may have two or more parts. The main types of flasks are:

- a) Snap Flask
- b) Tight or Box Flash

III. Patterns

A pattern is the replica of the desired casting used to produce a mould cavity into which liquid metal is poured. When patter packed in a suitable material produces a cavity called the mould. This cavity when filled with molten metal produces the desired casting.

IV. Moulding tools

- | | |
|-------------------|-----------------|
| 1) Shovel | 8) Bellows |
| 2) Riddle | 9) Swab |
| 3) Rammer | 10) Gate cutter |
| 4) Trowels | 11) Draw spike |
| 5) Slick | 12) Lifter |
| 6) Strike off bar | 13) Vent rod |
| 7) Sprue pin | |

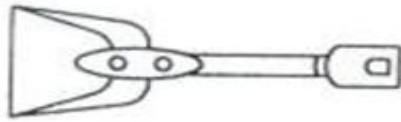

Shovel



Riddle

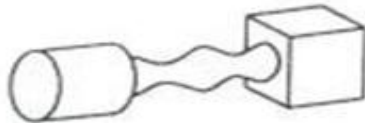

Rammer



Trowel



Slick



Lifter



Strike-off Bar



Sprue Pin



Bellow

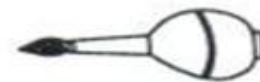

Brush



Gate Cutter



Vent Rod



Draw Spike

GEAR PATTERN

EX.NO:

DATE :

AIM:

To prepare a sand mould using a gear pattern

MATERIALS REQUIRED

Moulding sand, Parting sand, Facing sand, Gear pattern, Moulding boxes etc.

TOOLS REQUIRED

1. Showel
2. Sieve
3. Trowel
4. Rammers
5. Spure pin
6. Strike off bar
7. Lifter
8. Gate cutter
9. Runner
10. Riser
11. Vent rod
12. Draw spike
13. Bellow

SPECIMEN DRAWING:

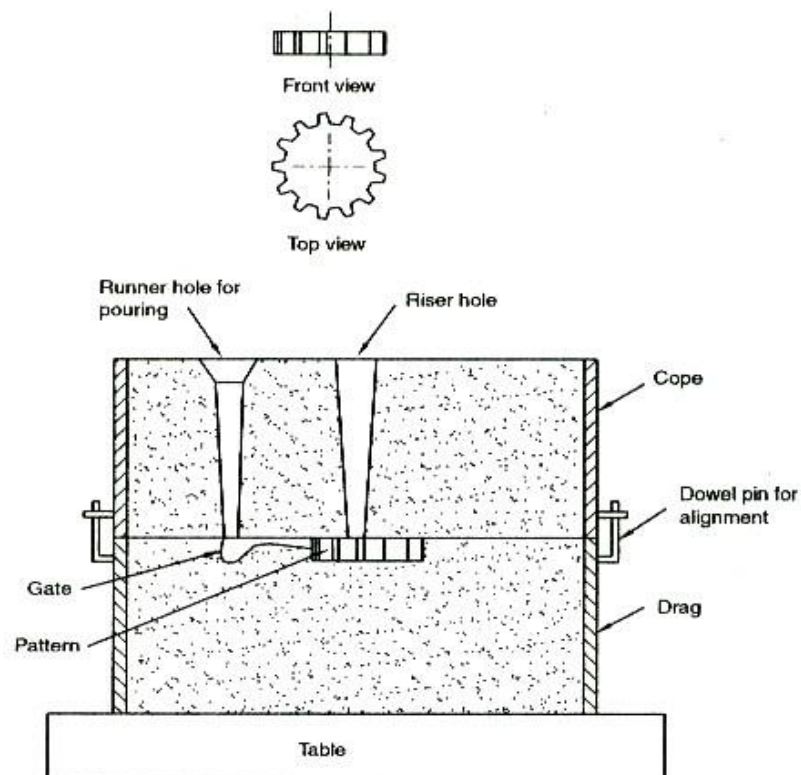

SEQUENCE OF OPERATIONS:

1. Sand preparation.
2. Core preparation.
3. Placing the pattern on moulding board.
4. Ramming of drag.
5. Placing runner and riser.
6. Ramming of cope.
7. Removal of pattern, runner, riser.
8. Gate cutting.

PROCEDURE:

1. The gear pattern is placed on the moulding board.
2. A suitable core is prepared and placed in the hole of gear pattern.
3. Clay washing is done inside the drag surface.
4. Parting sand is applied over the pattern.
5. Box is filled with smooth moulding sand and proper ramming is done using flat and peen rammers.
6. Excess sand is removed using the strike off bar.
7. The drag is turned upside down.
8. The cope is placed on the drag after doing clay wash.
9. The runner and riser are placed over the pattern.
10. After applying parting sand, moulding sand is filled over the pattern.
11. Ramming is done to get a rigid mould.
12. Using strike off bar excess sand is removed.
13. Vent holes are made using vent rod.
14. Runner and raiser are removed a funnel shape is made on the runner hole.
15. Cope is kept aside and the pattern is removed using draw spike.
16. The cope is placed on the drag.

RESULT: Thus the gear mould is prepared and ready for casting

STEPPED CONE PULLEY

EX.NO:

DATE :

AIM:

To prepare a sand mould using a flange pattern

MATERIALS REQUIRED

Moulding sand, Parting sand, Facing sand, Gear pattern, Moulding boxes etc.

TOOLS REQUIRED

1. Showel
2. Sieve
3. Trowel
4. Rammers
5. Spure pin
6. Strike off bar
7. Lifter
8. Gate cutter
9. Runner
10. Riser
11. Vent rod
12. Draw spike
13. Bellow

SPECIMEN DRAWING:

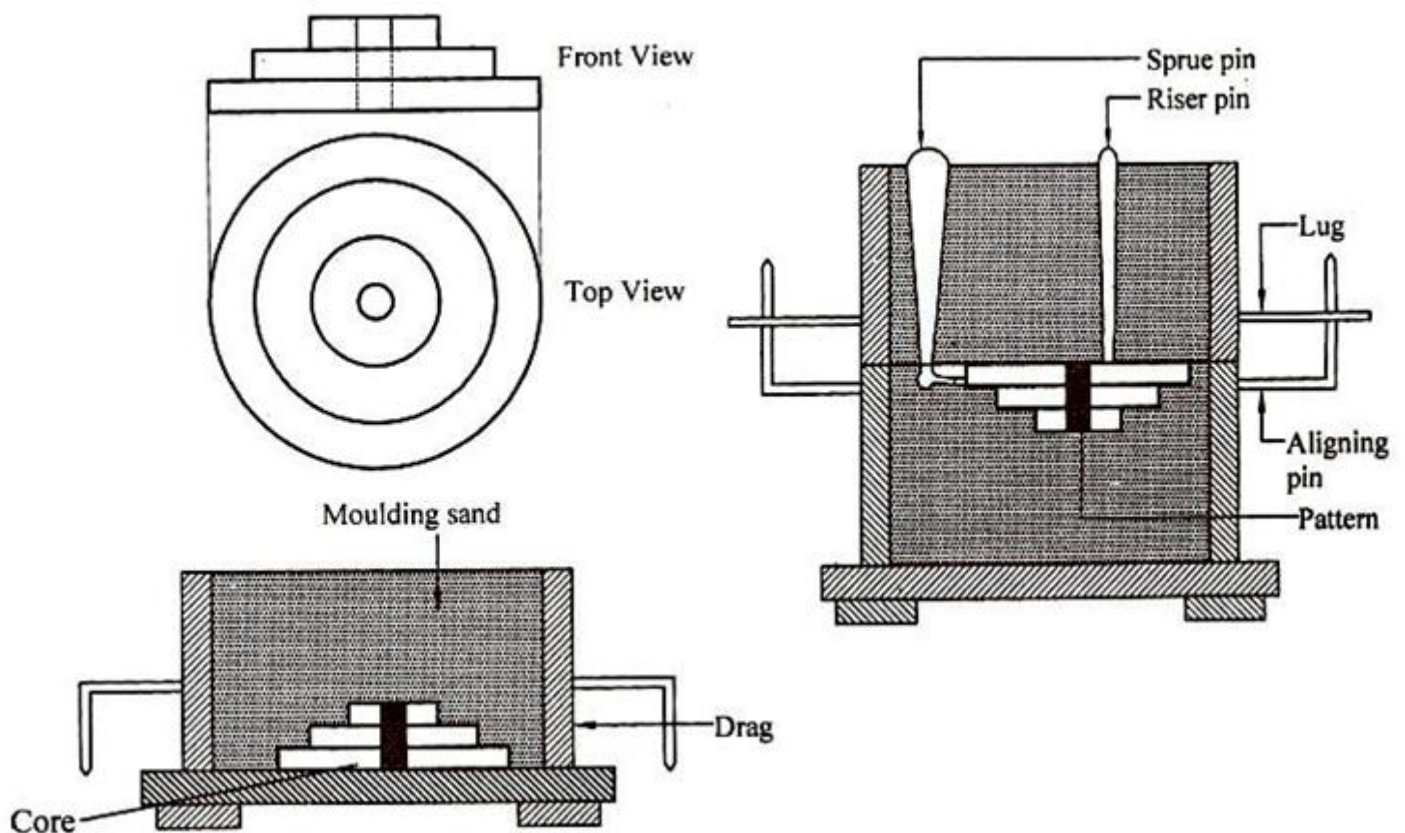

SEQUENCE OF OPERATIONS:

1. Sand preparation.
2. Core preparation.
3. Placing the pattern on moulding board.
4. Ramming of drag.
5. Placing runner and riser.
6. Ramming of cope.
7. Removal of pattern, runner, riser.
8. Gate cutting.

PROCEDURE:

1. The stepped pattern is placed on the moulding board.
2. A suitable core is prepared and placed in the hole of gear pattern.
3. Clay washing is done inside the drag surface.
4. Parting sand is applied over the pattern.
5. Box is filled with smooth moulding sand and proper ramming is done using flat and peen rammers.
6. Excess sand is removed using the strike off bar.
7. The drag is turned upside down.
8. The cope is placed on the drag after doing clay wash.
9. The runner and riser are placed over the pattern.
10. After applying parting sand, moulding sand is filled over the pattern.
11. Ramming is done to get a rigid mould.
12. Using strike off bar excess sand is removed.
13. Vent holes are made using vent rod.
14. Runner and raiser are removed a funnel shape is made on the runner hole.
15. Cope is kept aside and the pattern is removed using draw spike.
16. The cope is placed on the drag.

RESULT: Thus the stepped mould is prepared and ready for casting

VI. SHEET METAL

INTRODUCTION:

Sheet metal work is working on the metal of 16 gauge to 30 gauge with hand tools and simple machines into different forms by cutting, forming into shape and joining. Sheet metal work is one of the major applications in the engineering industry. It has its own significance as useful trade in engineering work.

Application of sheet metal:

Sheet metal work is used for making hoppers, funnels, various ducts, chimneys, ventilating pipes, machine tool guards, boilers, etc., It is also used in major industries like aircraft manufacturing, ship building, automobile body building and fabricating ducts in air conditioning equipments etc.,

Tools used:

Cutting tools (chisels, snips or shears):

Chisels:

Chisels are used for cutting sheets, rivets, bolts and clipping operations. Round nose chisel and flat chisel are the often used ones.

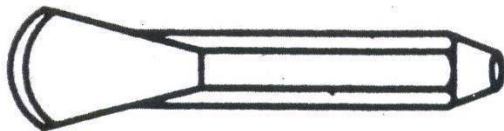

Flat Chisel



Round Nose Chisel

Snips or shears:

Snips are hard shears, varying in length from 200mm to 600mm. 200mm and 250mm length is commonly used. Straight snips are used for cutting along outside curves and straight lines. Curved snips or bent snips are used for trimming along inside curves.

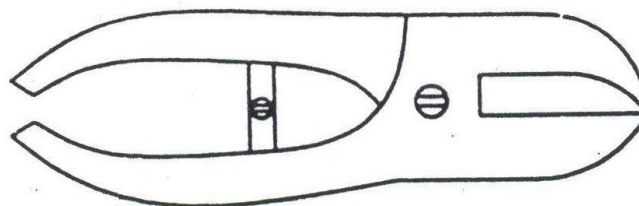

Straight Snip

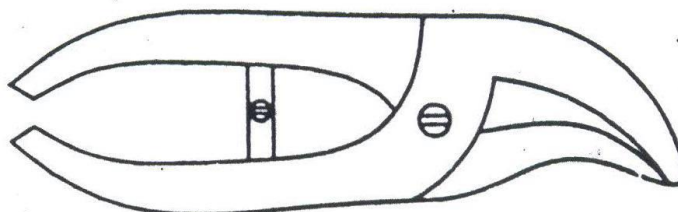

Bend Snip

Striking tools:**Hammer:**

Hammers are used in sheet metal work for hollowing, stretching, levelling, revetting, strengthening of sheet metal joints etc., the following joints are used in sheet metal. Ball peen hammer, Straight peen hammer, Rivetting hammer, Mallet

Punches:

In sheet metal work, punch is used for making out work locating centers etc., the following two types of punches are widely used. Dot punch & Centre punch.

Supporting tools:**Stakes:**

Stakes are nothing but sheet metal worker's anvils used for bending, hemming, seaming, forming etc., using hammers and mallet.

Bending tools:**Pliers:**

Pliers are used for bending the sheet metal to the required shape. It is also used for holding and cutting the sheet metal. Flat nose pliers and round nose pliers are used in sheet metal work for forming and holding work.

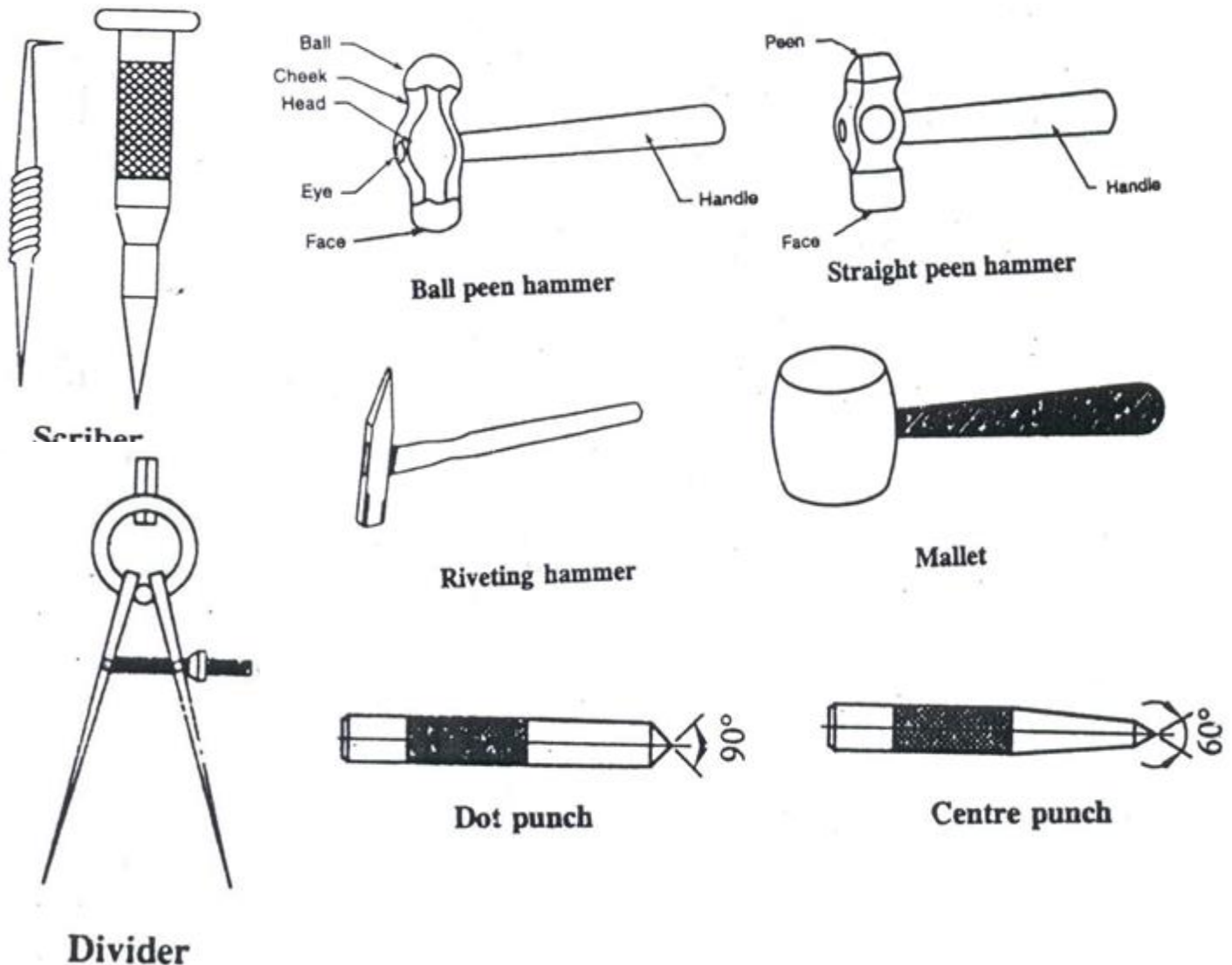

Layout tools:**Steel rule:**

It is used for measuring and laying out small work it can measure with as accuracy of up to 0.5mm.

Scriber:

It is a long wire of steel with its one end sharply pointed and hardened to scratch line on sheet metal for laying out patterns.

Dividers:

Dividers are used for drawing circles or arcs on sheet metal.

Trammels:

It is used for marking areas and circles. Maximum size of the arc that can be scribed depends on the length of the beam in scriber.

Sheet metal gauge:

It is used to find the thickness of the sheet metal. The various types of gauges are: Standard Wire Gauge (SWG), Birham Wire Gauge, Birmingham Wire Gauge and American Wire Gauge.

Other tools:**Grooving:**

In order to join the sheet metal joints, their ends are grooved with the help of grooving tools. This process is called grooving. It is a most widely used tool made up of hardened and tempered carbon steel. These are used for making locked joints in sheet metal works such as wired edges, slots etc., These are available in different sizes.

Bench plate:

A special type of plate made of carbon steel. Types of bench plate: fixed bench plate, revolving bench plate.

Hand dolly

It is a steel block rectangular in shape and fitted with a handle in the bottom of the block.

Sheet metal joints:

Sheet metal working incorporates a wide variety of hems and seams.

Hem:

A hem is an edge or border made by folding. Types of hem are Single hem, Double hem, wired edge.

RECTANGULAR TRAY

EX.NO:

DATE :

AIM:

To make a Rectangular Tray from the given sheet metal.

MATERIALS REQUIRED

22 gauge Galvanized Iron (G.I) sheet.

TOOLS REQUIRED

1. Steel rule
2. Mallet
3. Scriber
4. Divider
5. Protractor
6. Snips
7. Stakes
8. Rivet set
9. Ball peen hammer

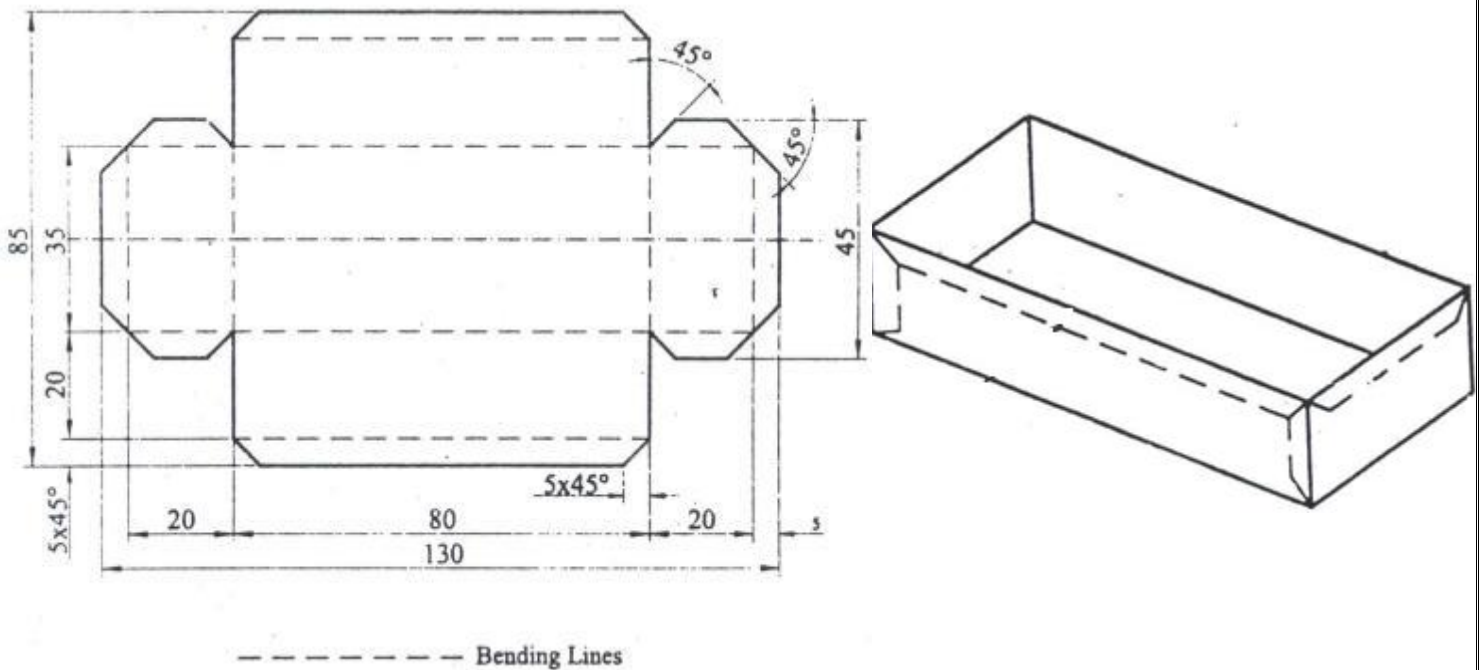
SPECIMEN DRAWING:

SEQUENCE OF OPERATIONS:

1. Checking
2. Levelling
3. Marking on paper
4. Marking on sheet metal
5. Cutting
6. Folding
7. Hemming
8. Soldering

PROCEDURE:

1. The gear pattern is placed on the moulding board.
2. The size of the given sheet metal is checked for its dimensions using a steel rule.
3. The required development of surface is being made on the white paper which is overlapped on the sheet metal.
4. The marking is done on the sheet metal as per the development being done on the paper.
5. Now using straight snips, unwanted materials are removed.
6. Now fold and bend the work piece to make the funnel shape and joint is made on the work piece.
7. Then using groover, locked grooved joint is made for about 5mm. Also, hemming is done in the bottom of the funnel.
8. In between top face and bottom face, butt joints is made using solder.
9. Finally, trimming and finishing operations are being carried out.

RESULT: Thus the desired rectangular tray is made from the given sheet metal.

FUNNEL

EX.NO:

DATE :

AIM:

To make a funnel from the given sheet metal.

MATERIALS REQUIRED

22 gauge Galvanized Iron (G.I) sheet.

TOOLS REQUIRED

1. Steel rule
2. Mallet
3. Scriber
4. Divider
5. Protractor
6. Snips
7. Stakes
8. Rivet set
9. Ball peen hammer

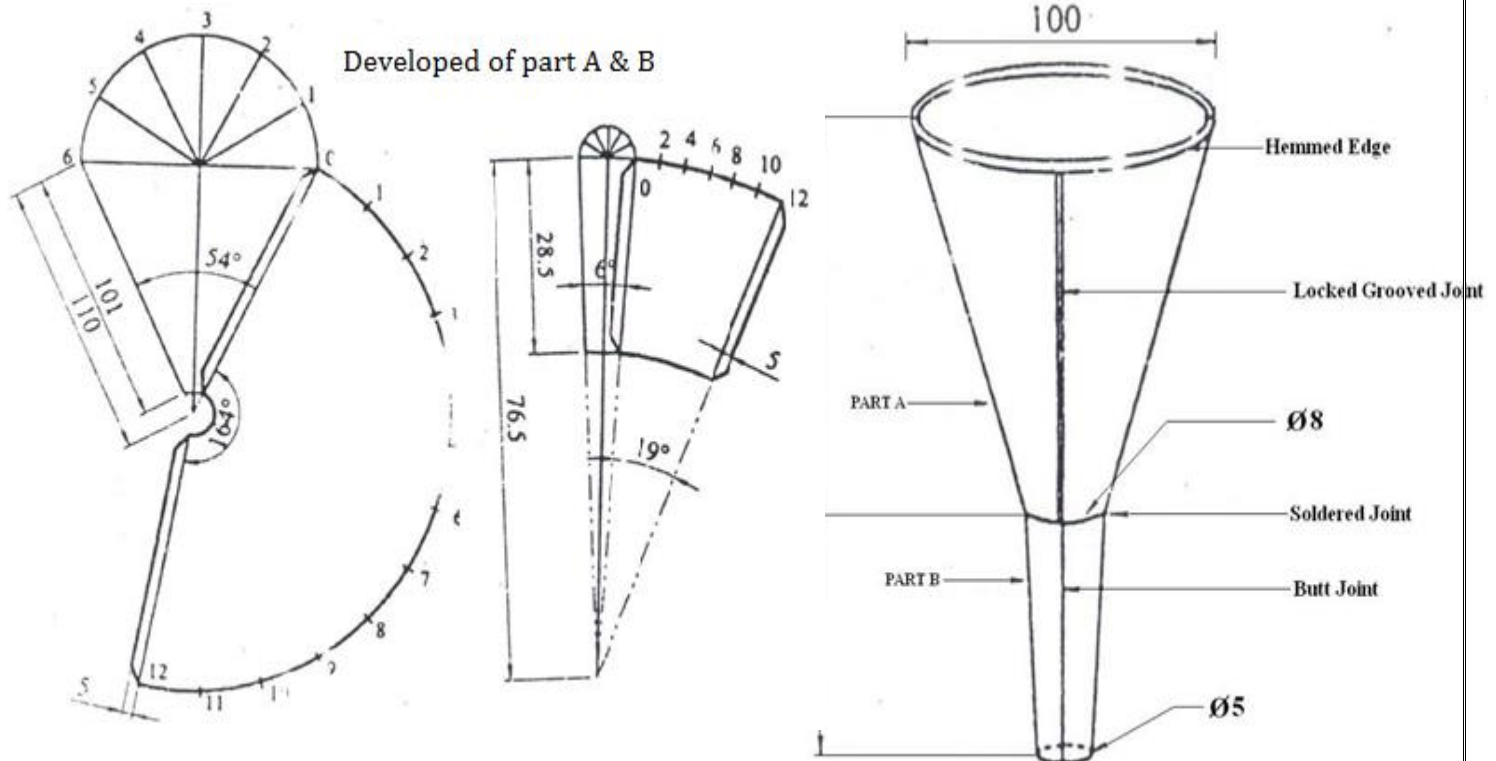
SPECIMEN DRAWING:

SEQUENCE OF OPERATIONS:

1. Checking
2. Levelling
3. Marking on paper
4. Marking on sheet metal
5. Cutting
6. Folding
7. Hemming
8. Soldering

PROCEDURE:

1. The gear pattern is placed on the moulding board.
2. The size of the given sheet metal is checked for its dimensions using a steel rule.
3. The required development of surface is being made on the white paper which is overlapped on the sheet metal.
4. The marking is done on the sheet metal as per the development being done on the paper.
5. Now using straight snips, unwanted materials are removed.
6. Now fold and bend the work piece to make the funnel shape and joint is made on the work piece.
7. Then using groover, locked grooved joint is made for about 5mm. Also, hemming is done in the bottom of the funnel.
8. In between top face and bottom face, butt joints is made using solder.
9. Finally, trimming and finishing operations are being carried out.

RESULT: Thus the funnel of the required dimensions is made from the given sheet metal

METAL SPINNING

EX.NO:

DATE :

AIM:

To make a component using Lathe machine by metal spinning process

MATERIALS REQUIRED

26 gauge Galvanized Iron (G.I) sheet.

TOOLS REQUIRED

1. Steel rule
2. Mallet
3. Scriber
4. Divider
5. Snips
6. Lubrication
7. Mandrel
8. Roller tool
9. Clamp

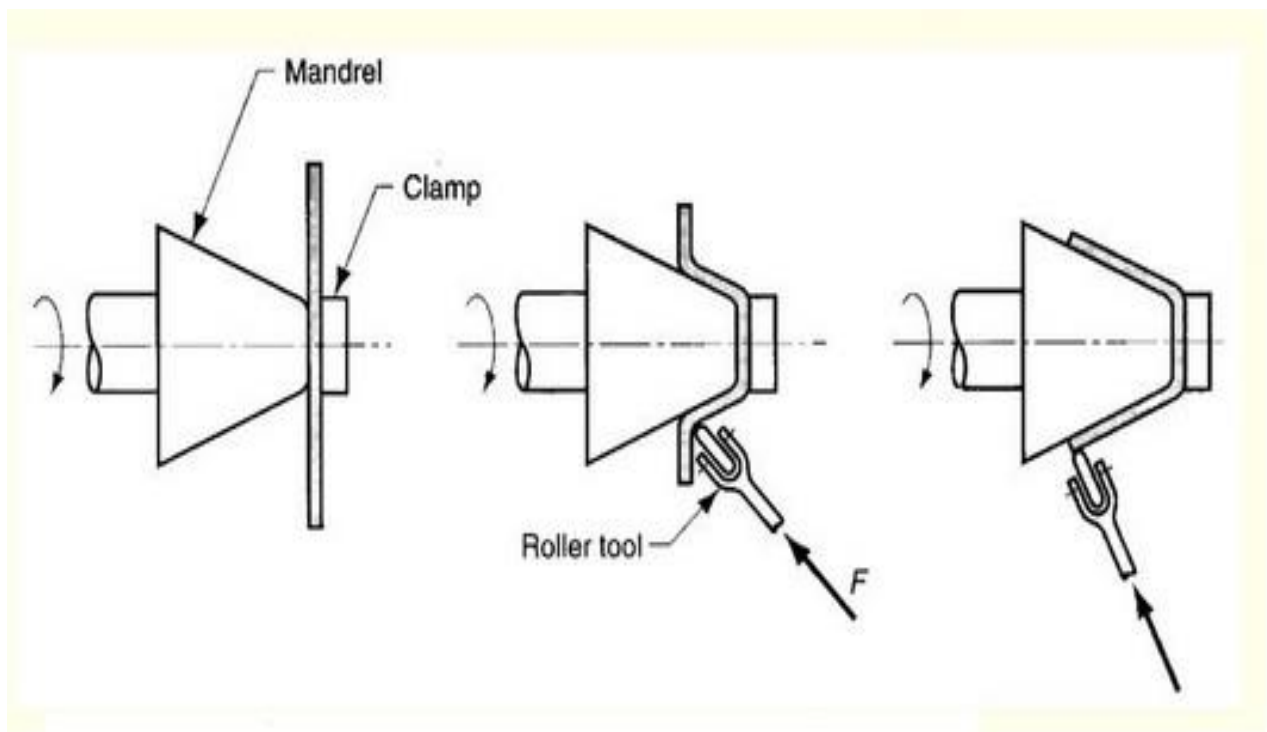
SPECIMEN DRAWING:

PROCEDURE:

1. First the work piece must be thoroughly cleaned to remove rust, scale and other foreign material.
2. The size of the given sheet is checked for its dimensions using a steel rule.
3. The required shape is first sniped from the metal sheet using snipping tool
4. Then the sheet is clamped to mandrel between head stock and tail stock.
5. The roller tool is placed over the jig of the lathe machine is turned on.
6. Using the roller tool force is applied manually over the metal sheet.
7. The metal sheet attains the external shape of the mandrel.
8. In general metal spinning process is achieved in two to three stages.
9. Edges of the metal sheet are then trimmed to avoid sharp points.

RESULT: Thus the metal spinning process is performed using lathe machine.

TAPER TURNING BY TAIL STOCK OFFSET METHOD

EX.NO:

DATE :

AIM:

To Produce the component by performing Taper Turning using lathe.

MATERIALS REQUIRED

Mild steel Φ 32 mm X 153 mm long.

TOOLS REQUIRED

1. Chuck key
2. Tool post spanner
3. Vernier caliper
4. Steel rule
5. Single point cutting tool
6. Revolving centre
7. Drill chuck with centre drill bit
8. Catch plate with dog carrier

SPECIMEN DRAWING:

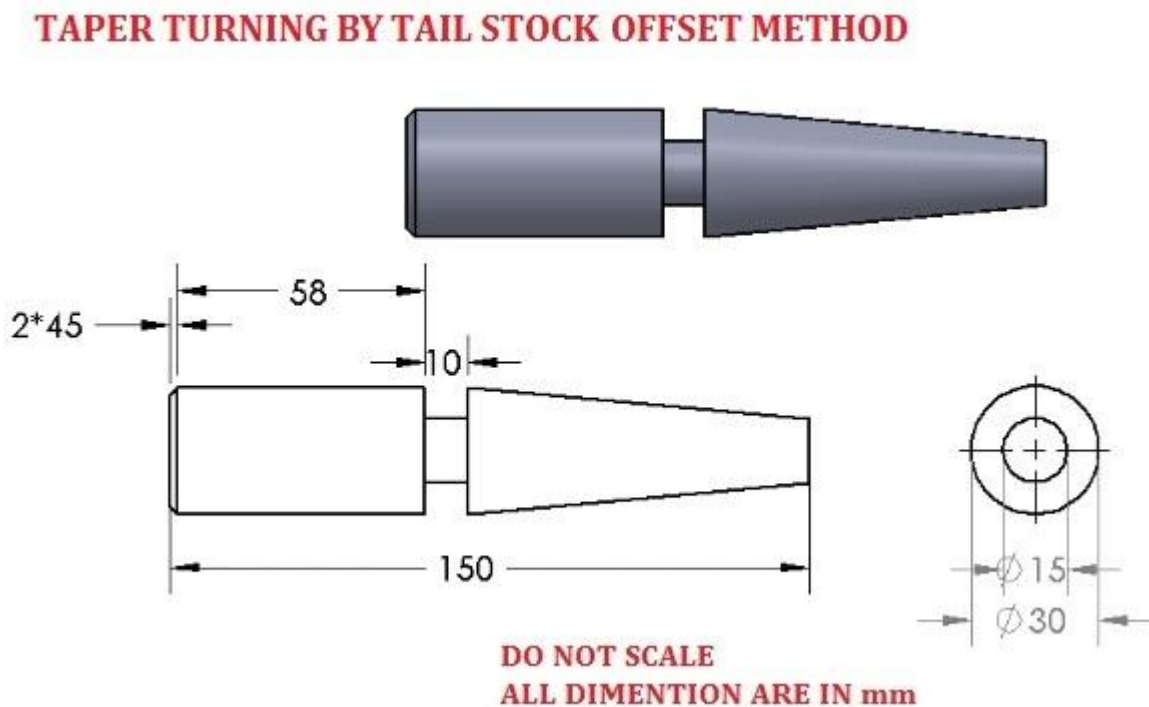

PROCEDURE:

1. Check the size of raw material given and ensure the size.
2. Held the work piece in the chuck and tight it properly.
3. Clamp the tool on tool post properly and check the center of work piece with cutting tool tip.
4. Do the facing operation by giving cross feed to the cross slide and reduce the length.
5. Do the turning operation by giving longitudinal feed to the carriage and reduce the diameter of the work piece.
6. Two or three passes can be given for turning operation.
7. Remove the work piece and hold in chuck on other side. Does the turning operation for the remaining portion of the work piece also do the facing operation and get the required length.
8. Make a center drilling operation on both sides by tail stock.
9. Calculate the offset distance and offset the tail stock from the lathe axis.
10. Hold the work piece between lathe centers on both side using catch plate with dog carrier.
11. Do the taper turning operation by giving longitudinal feed to the carriage as per the dimension.
12. Remove the component carefully and check the dimension.

RESULT: Thus the component is produced as per the given drawing using lathe.

KEY WAY SLOTTING

EX.NO:

DATE :

AIM:

To cut a keyway on the given specimen as per the dimensions using slotting machine.

MATERIALS REQUIRED

Cast iron blank of Φ 50mm x 10mm.

TOOLS REQUIRED

1. Steel rule
2. Vernier caliper (0-150mm)
3. T bolt strap
4. Spanner
5. punch

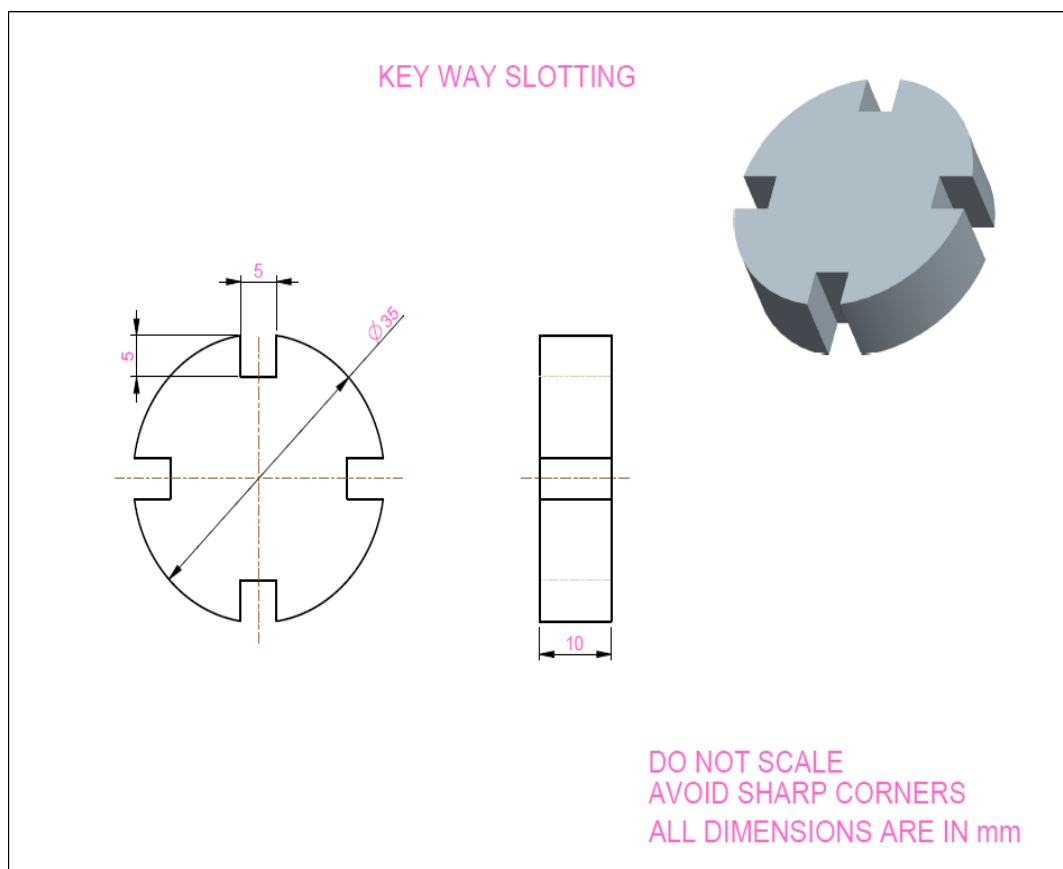
SPECIMEN DRAWING:

PROCEDURE:

1. First the given work piece is fitted on chuck and it is turned along the diameter to the required dimension by using lathe.
2. Then the facing operation is done on both the sides of the work piece.
3. Then the work piece is fixed in the slotting machine.
4. Indexing was done on the slotting machine.
5. By adjusting the feed hand wheel the key way are cut outer diameter of the work piece.
6. Then the same procedures are repeated for next key way.

RESULT: Thus the key way is made on the work piece by slotting machine.

SHAPING AN ANGULAR SURFACE

EX.NO:

DATE :

AIM:

To make an Angular surface by using a shaping machine.

MATERIALS REQUIRED

Cast iron blank of $\Phi 50 \times \Phi 50$

TOOLS REQUIRED

1. Machine handle
2. Vice handle
3. Round nose tool
4. Vernier caliper
5. Vernier height gauge
6. Tri-square
7. surface plate
8. Hammer and punch.

SPECIMEN DRAWING:

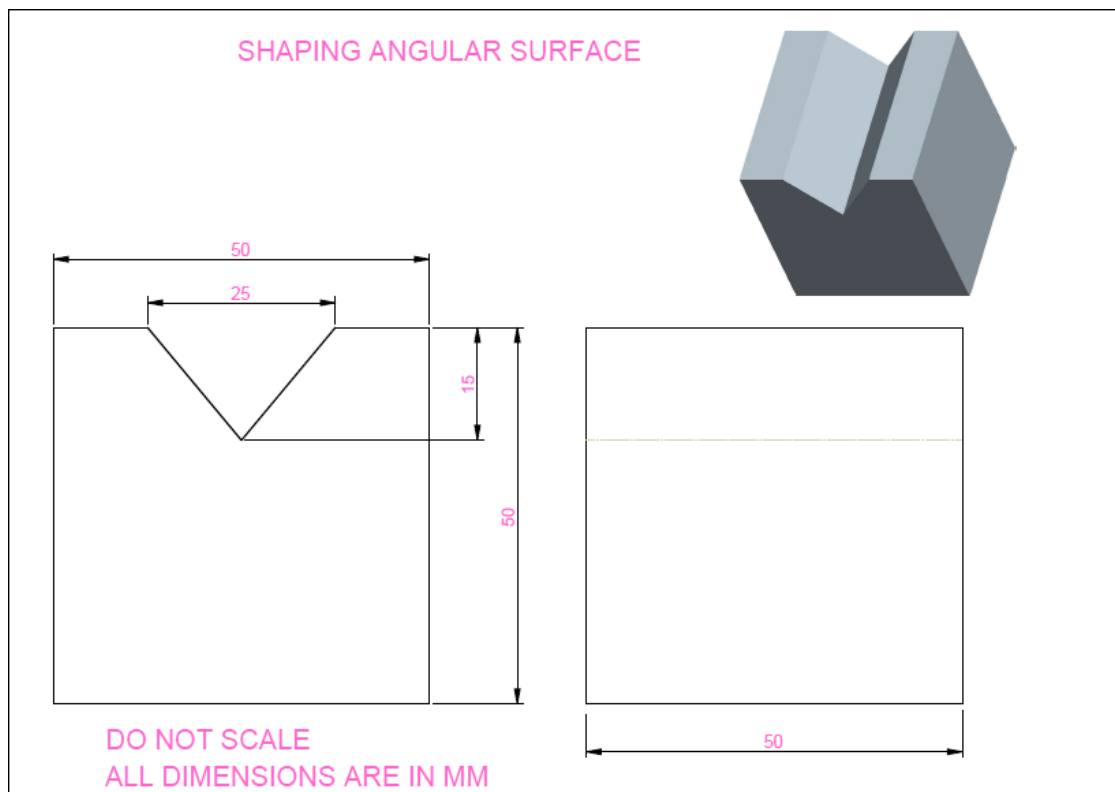

PROCEDURE:

1. Check the machine is in proper condition.
2. Check the work piece given in suitable size.
3. Select and set the correct stroke length, speed and feed.
4. The job is marked and punched. The punched job is set over the vice.
5. Hold the work piece in the vice and fix the tool in tool holder in correct position and start the machine.
6. Remove the material as per the size.
7. Remove the job and also remove the burrs with the help of files.

RESULT: Thus the shaping of angular surface operation is performed on the given work piece as per the dimension.

LAB VIVA QUESTIONS AND ANSWERS

1. What is a lathe?

Lathe is a machine, which removes the metal from a piece of work to the required shape & size

2. what are the various operations can be performed on a lathe?

- | | | |
|---------------|-------------------|--------------|
| 1. Turning | 6. Thread cutting | 11. Grooving |
| 2. Facing | 7. Drilling | |
| 3. Forming | 8. Boring | |
| 4. Knurling | 9. Recessing | |
| 5. Chamfering | 10. Tapping | |

3. What are principle parts of the lathe?

Headstock, tailstock, carriage, cross slide, tool post

4. What are the types of headstock?

Back geared type, all geared type

5. State the various parts mounted on the carriage?

Saddle, compound rest, cross slide, tool post

6. What is an apron?

The integral part of several gears, levers clutches mounted with the saddle for moving the carriage along with lead screw while thread cutting

7. List any four types of lathe?

1. Engine lathe
2. Bench lathe
3. Tool room lathe
4. Semi automatic lathe
5. Automatic lathe

8. What is a semi-automatic lathe?

The lathe in which all the machining operations are performed automatically and loading and unloading of work piece, coolant on or off is performed manually

9. State the various feed mechanisms used for obtaining automatic feed?

1. Tumbler gear mechanism
2. Quick change gearbox
3. Tumbler gear- Quick change gearbox
4. Apron mechanism

10. List any four holding devices?

1. Chucks
2. Centers
3. Face plate
4. Angle plate

11. What are the different operations performed on the lathe?

Centering, straight turning, rough turning, finish turning, shoulder turning, facing, chamfering, knurling, etc

12. What is tooling?

Planning of operations sequence & preparation of turret or capston lathe are termed as tool-layout or tooling

13. What are the three stage of a tool-layout?

1. Planning & scheduling
2. Detailed sketching of various machining operation sequence
3. Sketching the plan showing various tools

14. What is shaper?

The machine, which is having a reciprocating type of machine tool with a single point cutting tool, used to produce flat surfaces called as Shapers

15. List any four important parts of a Shaper?

Table, Tool head, Ram, Cross rail

16. How the feed & depth of cut is given to the shaper?

Feed is given by rotating the down feed screws of tool head depth of cut is given by rotating by raising or elevating the table

17. Mention any four-shaper specification?

1. Maximum length of stroke
2. Type of driving mechanism
3. Power of the motor
4. Speed & feed available

18. How the planer differs from the shaper?

In planer-the work reciprocate while the tool is stationary

In shaper-the tool reciprocate while the work is stationary

19. State the use of planer?

The planer is used for machining heavy & large casting Ex. lathe bed ways, machine guide ways

20. What is meant by drilling?

Drilling is the process of producing hole on the work piece by using a rotating cutter called drill

21. What is gang -drilling machine?

When a number of single spindles with essential speed & feed are mounted side by side on one base and have common worktable is known as gang -drilling machine

22. Mention any four specification of drilling machine?

1. Maximum size of the drill in mm that the machine can operate
2. Table size of maximum dimensions of a job can mount on a table in square meter
3. Maximum spindle travel in mm
4. Number of spindle speed & range of spindle speeds in r.p.m.

23. List any four machining operations that can be performed on a drilling machine?

1. Drilling
2. Counter sinking
3. Tapping
4. Trepanning

24. What are the different ways to mount the drilling tool?

1. Fitting directly in the spindle
2. By using a sleeve
3. By using a socket
4. By means of chucks

25. what is broaching?

Broaching is a process of machining a surface with a special multipoint cutting tool called broach which has successfully higher cutting edges in a fixed path

26. Indicate any two specification of a broaching machine?

1. Maximum length of stroke in mm
2. Maximum force developed by the slide in tones

27. What are the different operations that can be performed on a broaching machine?

1. Broaching splines
2. Broaching a key way

28. What is boring?

Boring is a process of enlarging & locating previously drilled holes with a single point cutting tool

29. What are the application of boring?

The boring machine is designed for machining large & heavy work piece in mass production work of engine frame, cylinder, machine housing etc

30. What is the function of cutting fluids?

1. It is used to cool the cutting tool & the work piece.
2. It improves the surface finish as stated earlier.
3. It causes the chips to break up into small parts.
4. It protects the finish surface from corrosion.
6. It prevents the corrosion of work & machine.

31. What are causes of wear?

The tool is subjected to three important factors such as force, temperature and sliding action due to relative motion between tool and the work piece. So the tool is wear easily.

32. What are the specifications of the milling machine?

1. The table length & width.
2. Number of spindle speeds & feeds.
3. Power of driving motor.

33. Mention the various movements of universal milling machine table?

1. Vertical movement-through the knee.
2. Cross vise movement-through the saddle.

34. What are the cutter holding devices?

1. Arbors
2. Adaptors
3. Collets

35. List the various type of milling attachment?

1. Vertical milling
2. Universal milling
3. High speed milling

36. Write any ten nomenclature of plain milling cutter?

Body of cutter, cutting edge, face, fillet, gash, lead, land, outside dia, root dia, cutter angles.

37. What are the down milling processes?

1. Cutter with higher rake angle can be used. This reduces power requirements.
2. Cutter wear is less because chip thickness is maximum at the start of cut.

38. List out the various milling operations?

1. Plain or slab milling.
2. Face milling.
3. Angular milling.
4. Gang milling.
5. End milling.
6. Gear cutting.

39. What does term indexing mean?

Indexing is the process of dividing the periphery of a job into equal number of divisions.

40. Mention the various parts of single point cutting tool?

1. Shank
2. Face
3. Flank
4. Base
5. Nose
6. Cutting edge

41. What is tool signature?

The various angles of tools are mentioned in a numerical number in particular order. that order is known as tool signature.

42. What is effect of back rake angle & mention the types?

Back rake angle of tool is increases the strength of cutting tool & cutting action. It can be classified in to two types

Positive rake angle

Negative rake angle

43. What is side rake angle & mention its effects?

The angle between the tool face & the line parallel to the base of the tool. it is used to control chip flow

44. Define orthogonal & oblique cutting?

Orthogonal cutting: The cutting edge of tool is perpendicular to the work piece axis.

Oblique cutting: The cutting edge is inclined at an acute angle with normal to the cutting velocity vector is called oblique cutting process

45. What is cutting force?

The sheared material begins to flow along the cutting tool face in the form of small pieces. The compressive force applied to form the chip is called cutting force

46. Define machinability of metal?

Machinability is defined as the ease with which the material can be satisfactorily machine.

47. What are the factors affecting the machinability?

1. Chemical composition of work piece material.
2. Microstructure of work piece material

48. What is machinability index?

It is the comparison of machinability different material to standard material. US material standards for 100% machinability are sae1112 hot rolled steel.

Machinability index $I = \frac{\text{Cutting speed of metal investigated for 20 minutes tool life}}{\text{Cutting speed of standard steel for 20 minutes tool life}}$

49. What are the factors affecting tool life?

1. Cutting speed
2. Feed & depth of cut
3. Tool geometry
4. Tool material

50. Express the Taylor's tool life equation?

Taylor's tool life equation: $VT^n = C$

V=Cutting speed in m/min T=Tool life in minutes

C=Constant

n=Index depends upon tool & work.