

Chapter 1

BASIC CONCEPTS AND DEFINITIONS

Thermodynamics is the science of energy transfer which deals with the relations among heat, work and properties of systems.

The name 'thermodynamics' is derived from the Greek words therme, meaning 'heat' and dynamis meaning power. Thus, thermodynamics is basically the study of heat and power.

1.1 Application Area of Thermodynamics

Energy transfer is present in almost all the engineering activities. Hence, the principles of thermodynamics are playing vital role in designing all the engineering equipments such as internal combustion engines, rockets, jet engines, thermal and nuclear power plants, refrigerators etc.

1.2 Statistical and Classical Thermodynamics

Statistical Thermodynamics is microscopic approach in which, the matter is assumed to be made of numerous individual molecules. Hence, it can be regarded as a branch of statistical mechanics dealing with the average behaviour of a large number of molecules.

Classical thermodynamics is macroscopic approach. Here, the matter is considered to be a continuum without any concern to its atomic structure.

Consider a gas in a container. Pressure exerted at the wall of the container is the average force per unit area due to the collision of the gas molecules on the wall surface. To determine this pressure, we need not know the behaviour of individual molecules of the gas. This approach is macroscopic approach. However, the results obtained from macroscopic and statistical study of matter.

1.3 Thermodynamic Systems and Surroundings

A Thermodynamic system is defined as a quantity of matter or a region in space whose behaviour is being investigated.

Everything external to the system is defined as surroundings. In its usual context the term 'surroundings' is restricted to the regions in the immediate vicinity which has a detectable influence on the system.

Boundary is the surface which separates the system from its surroundings. It may be fixed or moving and real or imaginary.

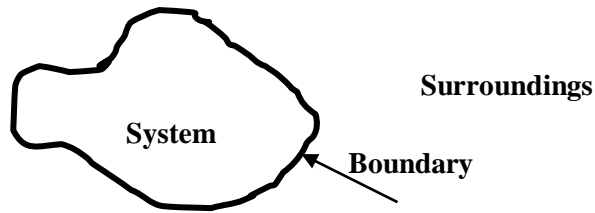

Fig.1.1 Thermodynamic System, boundary, surroundings

1.3.1 Types of Thermodynamic Systems

There are three types of thermodynamic systems :

- a) Closed System
- b) Open System and
- c) Isolated System

In closed system, attention is focused on a fixed mass. Energy in the form of heat and work (The terms heat and work will be defined in the chapter 2.) can cross the boundary of the system. But there is no mass flow across the boundary. Hence, the possibility of change in volume is always there in the closed systems.

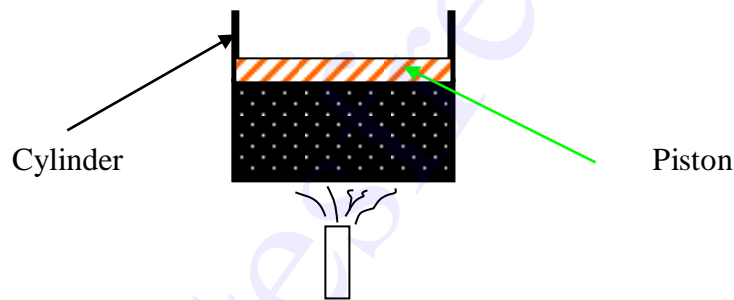

Fig.1.2 Closed system

In open system, both matter and energy can cross the boundary. Here, the behaviour of a fixed region in space called control volume is investigated and hence, there is no change in volume. The surface of the control volume is known as control surface.

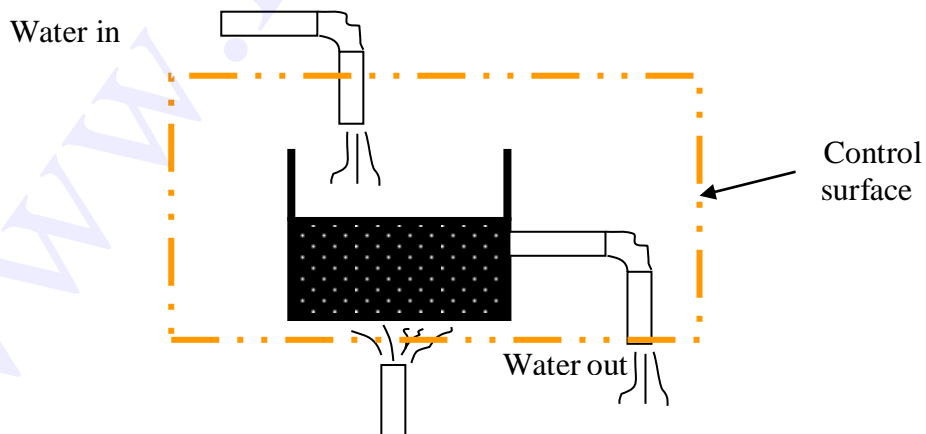

Fig.1.3 Open system

A system that exchanges neither energy nor matter with its surroundings is known as an isolated system.

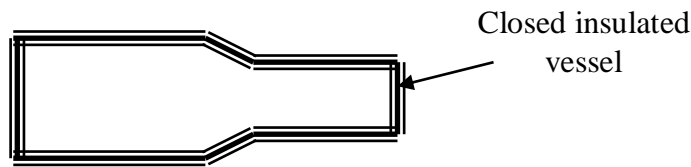

Fig.1.2 Isolated system

1.4 Thermodynamic Properties

In all thermodynamic problems energy transfer to or from the system is observed. To receive, store and deliver energy a working substance is present within the system. The characteristics which can be used to describe the condition of the system are known as properties.

Thermodynamic properties are classified into two categories : intensive and extensive. Intensive properties are independent of quantity of matter or mass whereas extensive properties are dependent on mass

Consider a vessel containing air. If a membrane is assumed to be introduced into the vessel, such that it is divided into two equal parts. The properties remaining unchanged such as pressure and temperature are intensive properties. Volume of air will be reduced to half of its initial value. Hence, it is an extensive property.

1.5 Thermodynamic State and Equilibrium

When a system does not undergo any change, all the properties have fixed values. This condition is known as a thermodynamic state.

The word equilibrium means balance. An equilibrium state of a thermodynamic system is a state that can not be changed without any interaction with its surroundings. The factors that cause a change without any interactions with its surroundings are:

1. Pressure difference
2. Temperature difference
3. Chemical reaction

If a system is balanced in all respects, it is in a state of thermodynamic equilibrium. Balanced in all respects means :

- There should not be any temperature difference within the system, so that the system is thermally balanced.
- No pressure difference exists between any two points within the system (Neglecting gravitational effects) and between the system and surroundings, so that it is mechanically balanced.
- No chemical reaction is taking place, so that it is chemically balanced.
- If two phases are involved, mass of each phase remains constant so that phase equilibrium is achieved.

Hence, for a system in a state of thermodynamic equilibrium, there is no change in any macroscopic property.

1.6 Processes and Cycles

When a system is taken from one equilibrium state to another, the change is known as process. The series of intermediate states through which a system passes during a process is called the path of the process. If all these intermediate states are equilibrium states, the process is known as quasi equilibrium or quasi-static process.

Consider a certain quantity of gas taken in a frictionless piston cylinder arrangement as shown in Fig 1.5. The system is in thermodynamic equilibrium so that there is no unbalanced force acting on piston.

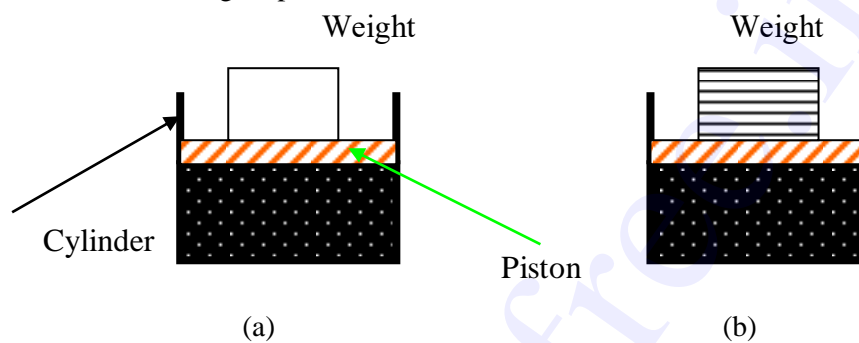

Fig.1.5 Illustration for thermodynamic equilibrium

The moment the weight is removed from the piston, mechanical equilibrium does not exist and as a result the piston is moved upward until mechanical equilibrium is restored again. Therefore the actual process occurs only when equilibrium does not exist.

As shown in Fig.1.5.a, if the entire weight on the piston is removed at once, the deviation from the equilibrium is high and the expansion is rapid. For such a process the intermediate states are not equilibrium states and hence the process would be non-quasi-equilibrium.

If the weight is assumed to be made of a large number of small pieces as shown in Fig.1.5.b and taken off one by one, the deviation from equilibrium is less. The process could be considered quasi-equilibrium.

A thermodynamic system is said to undergo a cycle, if it is taken through a number of processes such that, the final state of the last process is identical with the initial state of the first process in all respects. For cycles net change in any property is zero.

1.7 Point and Path Functions

Thermodynamic functions are classified into two categories namely point and path functions. Point functions are those for which the change depends on only the end states and not on the path followed. Hence point functions are inexact differentials

Path functions are those for which the change depends not only on the end states but also on the path followed. Hence path functions are exact differentials

It can be observed the change in any property during a process depends only on end states. Therefore all the properties are point functions.

To demonstrate path and point functions, let us consider two stations A and B on a hill as shown in the Fig.1.6. While moving from station A to station B, let the distance traveled and increase in height from the mean sea level are observed. Distance traveled in path 1 is different from that in path 2. Hence it may be regarded as path function. But the change in height is same in both path 1 and path 2, therefore it is a point function.

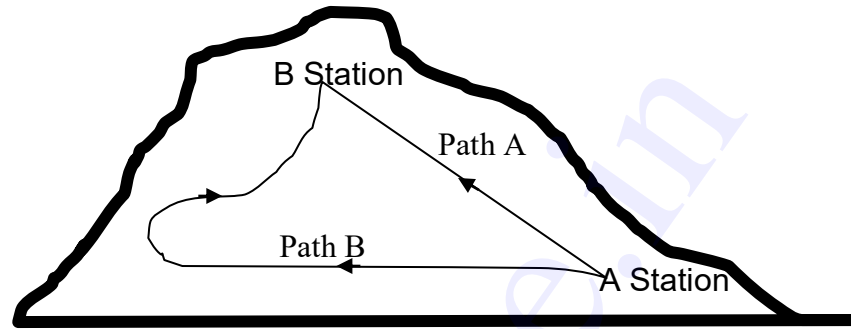

Fig.1.6 Illustration of point and path functions

1.8 State Postulate and Property Diagrams

As mentioned earlier, properties are meant for describing the state of a system. To fix a state, all the properties need not be specified. If any two independent intensive properties are specified, rest of the properties automatically assumes certain values. This is known as state postulate.

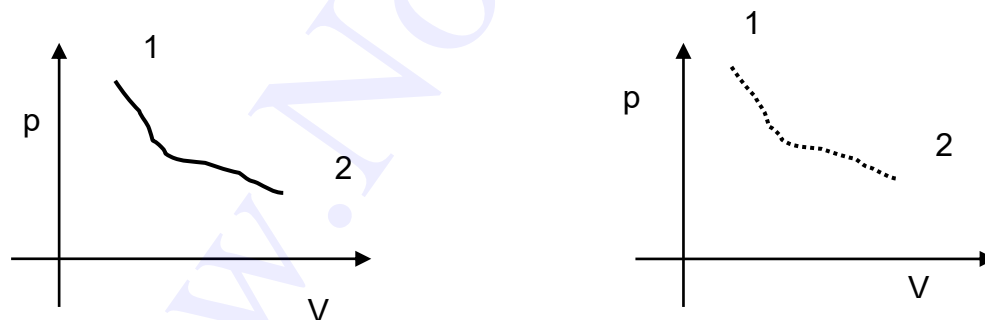

Fig.1.7 property diagram of equilibrium and non equilibrium processes

Consider pressure and specific volume (*Volume per unit mass*) are the two independent, intensive properties, describing the state of a compressible system. On a p-V diagram the state will assume a point as represented in the Fig.1.7(a). Let the system be taken to another state such that all the intermediate states are equilibrium states. The curve connecting the initial state and final state, passing through all the intermediate states is indicating the path of the process. In non-quasi-equilibrium process as the intermediate status can not be defined, the path is denoted by dashed line as given in Fig.1.7(b)

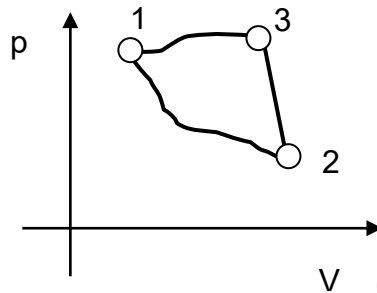

Fig. 1.8 Thermodynamic cycle on a property diagram

Fig.1.8 indicates a system undergoing a cycle consisting of three quasi-equilibrium processes.

1.9 Temperature and Zeroth Law

Maxwell defined the temperature of a system as *its Thermal state considered with reference to its ability to communicate heat to other bodies.*

When a hot body is brought into contact with a cold body, the hot body becomes cooler and the cold body becomes hotter. After sufficient time, the temperature of both the bodies will be equal. At that point, the two bodies are said to have reached thermal equilibrium.

Consider three bodies A, B and C. If the bodies A and B are in thermal equilibrium with C when brought into contact separately, they are also in thermal equilibrium with each other. This concept is known as zeroth law of thermodynamics.

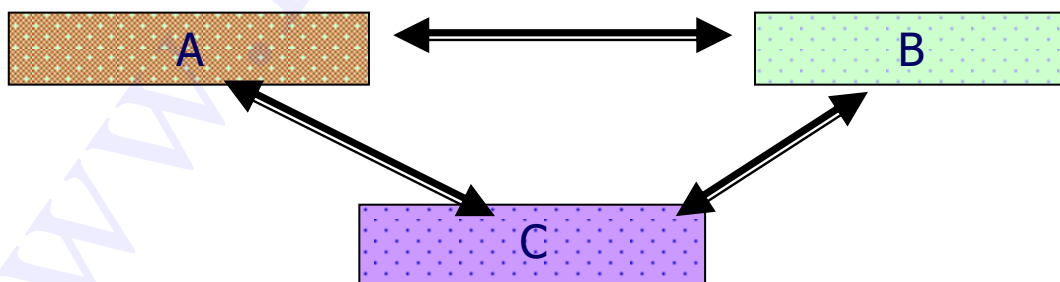

Several properties of materials are found to be varying with temperature in a predictable way. This variation is used to measure temperature. In mercury thermometers, expansion of mercury with temperature is used for temperature measurement.

1.10 Temperature Scales

Freezing point of water known as *ice point* and boiling point of water known as *steam point* are taken as the reference states for all types of temperature scales.

The various types as temperature scales in use are :

- Celsius scale
- Fahrenheit scale
- Kelvin scale
- Rankine scale

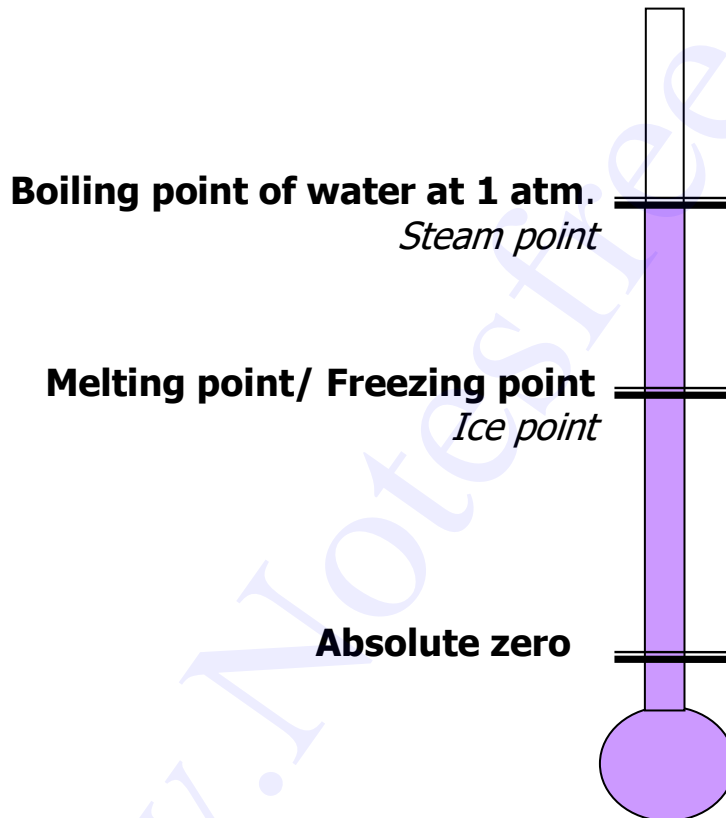

Reference state	Celsius	Kelvin	Fahrenheit	Rankine
Steam point	100	373	212	672
Ice point	0	273	32	492
Absolute Zero	-273	0	- 460	0

1.11 Homogeneous and Heterogeneous Systems

Matter can exist in any one of the three phases namely solid, liquid and gas. A system consisting of a single phase is known as homogeneous systems. If the matter exists in more than one phase, the system is known as heterogeneous system.

1.12 Pure Substances

Substances of fixed chemical composition throughout are known as pure substances. That is, pure substances have homogenous and invariable chemical composition irrespective of the phase or phases in which they exist.

Example

- a. Atmosphere air
- b. Water
- c. Nitrogen
- d. Water-steam mixture
- e. Product of combustion.

Though, mixture of water and steam is considered a pure substance, air and liquid air cannot be, since, the chemical composition of liquid air differs from that of gaseous air.

1.13 The Ideal Gas

Based on the experimental work carried out by Boyle, Charles and Gay-Lussac, pressure, temperature and specific volume of many gases at low pressure and moderate temperature are related by the following equation.

$$pv = RT \text{ where } R =$$

This equation is known as equation of state of an ideal gas. The term R is known as characteristic gas constant and R_u universal gas constant. In SI unit $R_u = 8.314 \text{ kJ/kgmol.K}$.

1.14 Concept of continuum

In microscopic approach the substance is assumed to be continuously distributed, ignoring the space between the molecules. This is known as continuum hypothesis.

Since the matter is treated as continuous, the density at a point can be defined as

$$\rho = \lim_{v \rightarrow v'} \left(\frac{m}{v} \right)$$

Where v' is the smallest volume for which a definite value of the ratio exists. Below the limiting value of v' , the fluctuation in average density will be high and a definite value for the ratio becomes impossible, with the *mean free path** of the molecules approaching the order of magnitude of the dimension of the vessel.

* *mean free path* is the distance traveled between two consecutive collisions of a molecule.

Exercises

1. Identify the type of the systems given below.
 - a) Reciprocating air compressor
 - b) Steam turbine in a steam power plant
 - c) Pressure cooker
 - d) Radiator of an automobile engine
 - e) A can of soft drink cooled inside the refrigerator
2. In _____ system control volume approach is employed.
3. Define a quasi-equilibrium process.
4. Define intensive and Extensive properties. Give examples.
5. What is the state postulate ?
6. What is zeroth law of thermodynamics ?
7. When does the concept of continuum become invalid ?
8. In which type of system neither mass nor energy is allowed to cross the boundary.
9. What is meant by thermodynamic equilibrium?
10. What is meant by a control surface?
11. What is meant by microscopic and macroscopic approach?
12. Universal gas constant = Characteristic Gas constant \times Molecular weight (T/F)
13. What is an open system? Give examples.
14. Define a closed system. Give examples.

Chapter 2

WORK AND HEAT

In the previous chapter, the different thermodynamic systems and their characteristics were discussed. To undergo a change of state, the system has to interact with its surroundings. Work and heat transfers across the boundaries cause these changes. In this chapter various forms of work and modes of heat transfers are discussed.

2.1 Work as Defined in Mechanics

work is done when the point of application of a force moves in the direction of the force. The product of the force and the distance moved in the direction of the force is equal to the amount of the work done.

This simple definition of work confines only to the area of mechanics and can not be extended to the more complex problems in thermodynamics. Hence a new definition should be introduced to cover mechanical as well as the other forms of work.

2.2 The Thermodynamic Definition of Work

Positive work is done by a system, during a given process, when sole effect external to the system could be reduced to the lifting of a mass.

Consider a gas expanding in a piston cylinder arrangement as given in Figure 2.1. Here no mass is actually lifted against gravity. But if the existing surroundings is fitted with an arrangement as given in the Figure 2.2, there is a possibility of lifting the mass. Hence work is said to be done by the system.

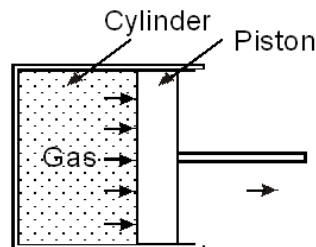

Figure 2.1 Expansion without actual lifting of mass

While exploring the possibility of lifting a mass the effects that are external to the system alone must be taken into account. For example, a lift with a person and a suitcase is considered as a system. If the person lifts the suitcase, it should not be taken into account, because this event occurs within the system.

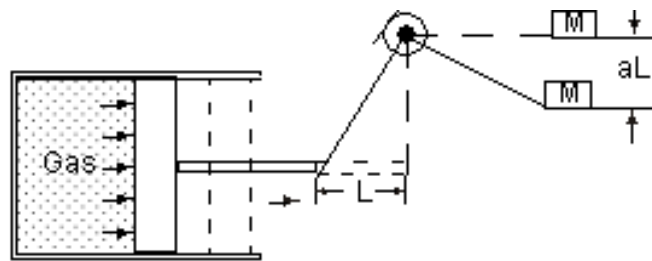

Figure 2.2 Expansion with actual lifting of mass

2.3 Units of Work and Power

In the international system (SI), the unit of force is Newton (N) and that of distance is metre (m). Hence the unit of work is Nm which is also given a special name Joule. In most of the applications large quantity of work is involved. Therefore kJ is commonly used.

Rate of doing work is known as power. Hence its unit is Nm/S or J/S which is again given a special name Watts(W).

2.4. Sign Convention of Work

- Work done by the system on the surroundings is considered as positive work.
- Work done on the system by the surroundings is taken as negative work.

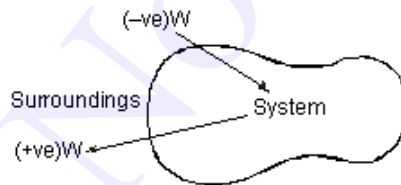

Figure 2.3 Sign Convention of work

2.5. Displacement Work

Consider a piston cylinder arrangement as given in the Figure 2.4. If the pressure of the fluid is greater than that of the surroundings, there will be an unbalanced force on the face of the piston. Hence, the piston will move towards right.

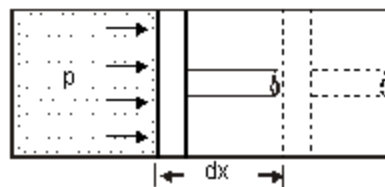

Figure 2.4 Displacement work

$$\begin{aligned}
 \text{Force acting on the piston} &= \text{Pressure} \times \text{Area} \\
 &= pA \\
 \therefore \text{Work done} &= \text{Force} \times \text{distance} \\
 &= pA \times dx \\
 &= pdV
 \end{aligned}$$

where dV - change in volume.

This work is known as displacement work or pdV work corresponding to the elemental displacement dx . To obtain the total work done in a process, this elemental work must be added from the initial state to the final state. Mathematically, .

2.6 Evaluation of Displacement Work

2.6.1.Constant Pressure Process

Figure 2.5 shows a piston cylinder arrangement containing a fluid. Let the fluid expands such that the pressure of the fluid remains constant throughout the process. Figure 2.6 shows the process in a p - V diagram.

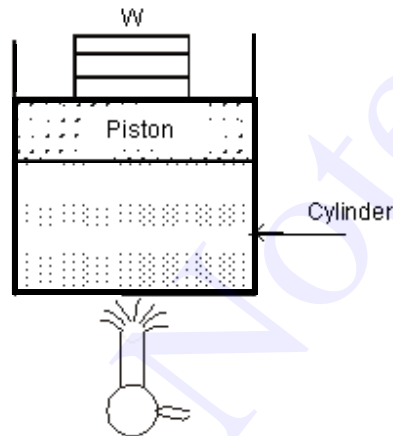

Figure 2.5

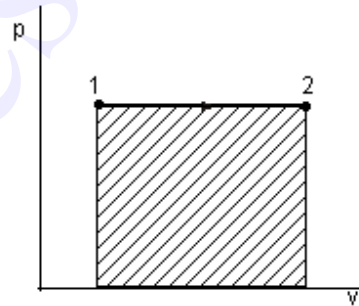

Figure 2.6

The mathematical expression for displacement work can be obtained as follows:

$$= p(V_2 - V_1) \quad \dots(2.1)$$

This expression shows that the area under a curve in a p - V diagram gives work done in the process.

2.6.2.Constant volume process

Consider a gas contained in a rigid vessel being heated. Since there is no change in volume, the displacement work .

2.6.3 Hyperbolic process

Let the product of pressure and volume remains constant at all the intermediate states of a process. In the p-V diagram it will be a hyperbola as given in Figure 2.7.

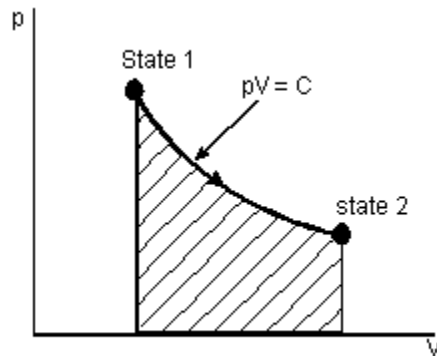

Figure 2.7

$$\begin{aligned}
 {}_1W_2 &= \int_1^2 p dV \\
 &= \int_1^2 C dV \text{ where } C=pV \\
 &= C \int_1^2 \frac{1}{V} dV \\
 &= C \ln(V_2/V_1) \\
 &= p_1 V_1 \ln(V_2/V_1) \text{ (or) } p_2 V_2 \ln(V_2/V_1) \quad \dots(2.2)
 \end{aligned}$$

For Ideal gases when temperature remains constant, pV will be constant i.e., isothermal process are hyperbolic processes for an ideal gas.

2.6.4 Polytropic Process

Any process can be represented by the general form $pV^n = \text{constant}$. Based on the value of n , the process differs as given below; For other values of n , the process is known as polytropic process. Figure 2.8 shows the polytropic process of various possible polytropic index ' n ' on p-V coordinates. Expression for displacements work for a polytropic process can be obtained as follows :

$$\begin{aligned}
 {}_1W_2 &= \int_1^2 p dV \\
 &= \int_1^2 \frac{C}{V^n} dV \text{ where } C = pV^n
 \end{aligned}$$

$$\begin{aligned}
&= C \int_1^2 V^{-n} dV \\
&= C \left[\frac{V^{-n+1}}{-n+1} \right]_1^2 \\
&= \left[\frac{CV_2^{-n+1} - CV_1^{-n+1}}{-n+1} \right]_1^2 \\
&= \left[\frac{p_2 V_2^n V_2^{-n+1} - p_1 V_1^n V_1^{-n+1}}{-n+1} \right] \quad \text{since } C = p_1 V_1^n = p_2 V_2^n \\
&= \left[\frac{p_2 V_2 - p_1 V_1}{-n+1} \right] \quad \dots(2.3)
\end{aligned}$$

2.7 Work is a Path Function

Consider a working substance initially occupying 0.2 m³ at 1 bar as represented by state 1 in the Figure 2.9. Let the system changes its state such that the final volume is 0.05m³ and pressure 2 bar. The change of state may occur along the paths 1A2,1B2 or 1C2. As mentioned earlier, area under the curve representing the process in a p-V diagram gives the work done in the process. Comparing the area under the paths 1A2, 1B2 and 1C2, it is clear that the work done in these paths are different. Hence it can be concluded that the amount of work done is not only a function of the end states of a process, but also the path followed between the states. Therefore work is a path function.

2.8 Additivity of Work Over Processes

If a system is taken through two or more number of processes, the total work done is the sum of work done in the individual processes.

Let a system executes three processes as shown in Figure 2.10. The total work done,

$$W_{14} = W_{12} + W_{23} + W_{34} \quad \dots(2.4)$$

2.11 Heat

Heat is the interaction between systems which occurs by virtue of their temperature difference when they communicate.

If a system, at a given temperature is brought in contact with another system (or surroundings) at a lower temperature, it can be observed that heat is transferred from the system at the higher temperature to the system at lower temperature. This heat transfer occurs solely because of the temperature difference between the two systems. Another important aspect of the

definition of heat is that a body never contains heat. Rather, heat can be identified only as it crosses the boundary. Similar to work, heat is also a form of energy transfer occurring at the boundary of the system and is a path function.

2.12 Sign Convention of Heat

- Heat given into a system is positive
- Heat coming out of the system is negative

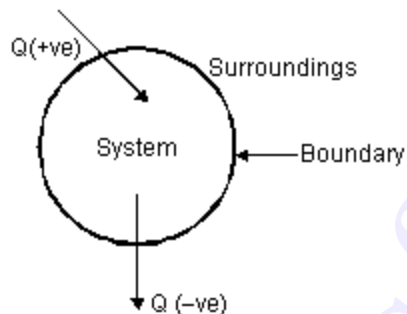

Fig. 2.8 Sign convention of work

2.13 Modes of Heat Exchange

Conduction, convection and radiation are the three possible modes of heat transfer between systems and between system and its surroundings.

Conduction occurs without bulk movement of molecules. Energy transfer in conduction is due to lattice vibration and free electron movement. It is the predominant mode of heat transfer in solids.

Convection occurs with bulk movement of molecules and therefore, occurs in gases and liquids. If the bulk movement or flow is due to an external device, it is known as forced convection. In the absence of an external device the flow is due to the difference in density caused by the temperature difference. This mode is known as natural convection.

Bodies separated by a distance may exchange heat in the form of electromagnetic waves without the participation of the intervening medium. It is known as radiation. It is generally a surface phenomenon. Sometimes as in the case of gas mixtures containing carbon dioxide and water vapour it is a volume phenomenon.

2.14 Sensible and Latent Heat

It is known that a substance can exist in three phases namely solid, liquid and gas. When a substance is heated or cooled temperature of the substance increases or decreases respectively unless there is any phase change. Quantity of heat added or removed to change the temperature by unit degree is known as specific heat. For solids and liquids same quantity of heat is required to cause unit degree rise for both constant pressure heating as well as constant volume heating as

they are incompressible. But for gases there is appreciable difference in the quantity of heat required to cause unit difference in temperature between constant volume and constant pressure processes. Accordingly, they are known as specific heat at constant volume (C_v) and specific heat at constant pressure (C_p). Thus to increase the temperature of m kg of the given substance by ΔT degree, amount of heat required is given by

$$Q = mC_v\Delta T \text{ at Constant Volume} \quad \dots(2.5)$$

$$Q_1 = mC_p\Delta T \text{ at Constant Pressure} \quad \dots(2.6)$$

If a certain single component system is undergoing phase change at constant pressure, temperature of the system remains constant during heating or cooling. Quantity of heat removed or added to cause the change of phase of unit mass of the substance is known as latent heat. For example latent heat of fusion of water is the amount of heat to be removed to solidify 1 kg of water into 1 kg of ice at a given temperature.

Let us consider a process of converting 1 kg of ice at -30°C to system to steam at 250°C at atmospheric pressure. We know that ice melts at 0°C and water evaporates at 100°C at atmospheric pressure.

For a constant rate of heating, if temperature at different instants are plotted we will get a graph as shown in Figure 2.9.

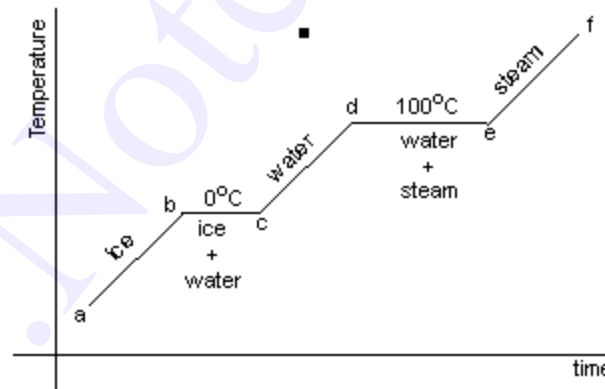

Figure 2.9 Illustration for sensible and latent heat

The total heat required can be obtained as follows:

$$Q = Q_{ab} + Q_{bc} + Q_{cd} + Q_{de} + Q_{ef} \quad \dots(2.7)$$

$$Q_{ab} = mC_{ice} (t_b - t_c) \quad \dots(2.8)$$

$$Q_{bc} = \text{Latent heat of melting of ice at } 0^\circ\text{C}$$

$$Q_{cd} = mC_{water} (t_d - t_c) \quad \dots(2.9)$$

$$Q_{de} = \text{Latent heat of evaporation of water at } 100^{\circ}\text{C}$$

$$Q_{ef} = mC_{P\text{Steam}}(t_f - t_e) \quad \dots(2.10)$$

Where C_{ice} = Specific heat of ice

C_{water} = Specific heat of water

$C_{P\text{Steam}}$ = Specific heat of steam at constant pressure

2.15 Reversible Adiabatic Process

A reversible process during which, the system and the surroundings do not exchange any heat across the boundary is known as reversible adiabatic process. For such a process, pressure and volume variation is governed by the law :

$$pV^{\gamma} = \text{constant} \quad \dots(2.11)$$

Where

C_p is the specific heat at constant pressure

C_v is the specific heat at constant volume

Detailed discussion on these specific heats is presented in the next chapter.

A wall which does not permit the heat flow across it is known as adiabatic wall, whereas the wall that permits the heat is known as diathermic wall. In an adiabatic process the only possible energy interaction across the boundary of the system is work transfer to or from the system.

Displacement work involved in a reversible adiabatic process can be expressed as

$$W = \left[\frac{p_2V_2 - p_1V_1}{-\gamma + 1} \right] \quad \dots(2.12)$$

2.16 Comparison between work and heat

- Both heat and work are boundary phenomena, that is, they occur only at the boundary.
- The interaction due to the temperature difference is heat and all other interactions are to be taken as work.
- Both work and heat are path functions, that is, they are inexact differentials.

Exercises

1. Name the forms of energy transfer across the boundary of a thermodynamic system.
2. State the thermodynamics definition of work.
3. Displacement work is not applicable to _____ systems.
4. The polytropic index n of process can be represented by
a) $n =$ b) $n =$ c) $n =$
choose the right answer.
5. What are point and path functions? Give examples.
6. What is meant by displacement work?
7. What is meant by an indicator diagram?
8. Define mean effective pressure.
9. What are the modes of heat transfer?
10. A certain fluid expands in a quasi-static process from 0.1 m^3 to 0.8 m^3 at a constant pressure of 1000 kPa. Find the work done. **[700 kJ]**
11. Zeroth law of thermodynamics is the basis of _____
a) Temperature measurement c) Heat measurement
b) Pressure measurement d) Internal energy
e) Enthalpy
Choose the correct answer
12. Mass remains constant for a closed system (T / F)
13. What are the similarities between work and heat?
 14. Calculate the work required to lift a 25 kg body from an elevation of 200 m above mean sea level to an elevation of 300 m in 2 minutes. **[24.525 kJ]**
15. What is the work done in compressing a spring of stiffness 500 N/cm by 2 cm? **[1 kJ]**
16. An electric water with a resistance of 50 Ohms heater is connected across a power supply of 240 Volt for a period of 1 hour.
 - a) Determine the work done by the power source on the heater.
 - b) How many units of electricity are consumed? **[5184 kJ; 1.44 k Whr]**
17. A gas is contained in a piston cylinder arrangement as given in the Figure 2.28. Initial volume of the gas is 0.5 m^3 . It is compressed from 1 bar to 10 bar such that the temperature remains constant. Find the final volume and work done. **[0.05 m³ ; -115.13 kJ]**

18. Air expands from 0.1 m^3 to 0.23 m^3 at a constant temperature of 50°C . Calculate the work done per kg of air. $R_{\text{air}} = 0.287 \text{ kJ/kgK}$.

[77.2 kJ]

19. Oxygen contained in a cylinder fitted with a piston expands in a quasistatic process according to the law $pV^{1.5} = \text{constant}$. The initial pressure, temperature and volume are 5 bar, 300 k and 0.05 m^3 . After expansion, the pressure is 2 bar.

Find the following :

- Final volume
- Final temperature
- Work done

[0.0921 m^3 ; 221 K ; 13.16 kJ]

20. Air is compressed adiabatically from 0.92 m^3 to 0.29 m^3 in a piston cylinder arrangement. Taking its initial pressure and temperature as 103 kPa and 300 k respectively, find the work done. Also find the final temperature.

[-139.04 kJ ; 476 K]

21. A spherical balloon has a diameter of 25 cm and contains air at a pressure of 150 kPa. The diameter of the balloon increases to 30 cm because of heating, and during this process, the pressure is proportional to the diameter. Calculate the work done on the gas assuming reversible work interaction.

[0.989 kJ]

22. A bicycle pump has a total stroke of 25 cm and is used to pump air into a tyre against a pressure of 3.5 bar. Calculate the length stroke necessary before air enters the tyre when the piston is pushed in

- rapidly
- slowly

Assume atmospheric pressure is 1 bar.

[17.0 cm ; 17.9 cm]

23. A mass of air occupying 0.5 m^3 at 2 bar and 200°C is compressed reversibly and adiabatically to 5 bar and then it undergoes isobaric expansion so that it gives out 45 kJ of work. If the system is to be brought back to its initial state what should be the polytropic index ? calculate the network interaction of this cycle. Sketch the cycle on a p-V diagram. Also compute the power developed if the number of cycles executed per minute is 300.

[2.57 ; 17.8 kJ ; 88.9 kW]

24. It is required to lift five people on an elevator through a height of 100 m. The work required is found to be 341.2 kJ and the gravitational acceleration is 9.75 m/s^2 . Determine the average mass per person.
- [69.95 kg]**
25. What is the work required to accelerate a vehicle of mass 500 kg from rest to a velocity of 60 kmph.
- [69.44 kJ]**
26. The indicator card of an 8 cm bore, 10 cm stroke water pump is in the shape of a rectangle of dimension $2 \times 10 \text{ cm}$. The indicator spring constant is 22 MPa/m.
- a) Find the mean effective pressure.
- b) If the cycle is repeated once in every second, what is the power required by the pump?
- [440 kPa ; 0.22 kW]**
27. A quantity of a substance in a closed vessel is undergoing a reversible process in such a way that the pressure is proportional to the square root of volume from 1 m^3 to 2 m^3 . The initial pressure is 100 KPa. Compute the work done.
- [2.33 kJ]**
28. A cylinder of 8 cm internal diameter is fitted with a piston loaded by a coil spring of stiffness 140 N/cm of compression. The cylinder contains 0.0005 m^3 of air at 15°C and 3 bar. Find the work done when the piston moves by 4 cm as the gas expands.
- [7.11 J]**
29. Carbon dioxide is taken in a piston cylinder arrangement such that it occupies a volume of 1 m^3 at 1 bar and 27°C . It has to be compressed to 0.2 m^3 such that the temperature remains constant during compression. Compute the work done and final pressure.
- [-160.94 kJ; 500 kPa]**
30. 5 kg of oxygen initially at 10 bar, 370 K is undergoing expansion to 1 bar. If the final temperature is 300K. Determine the following:
- a) Initial volume
- b) Final volume
- c) Polytropic index
- d) Work done
- Take the molecular weight of oxygen as 32.
- [0.48m³ ; 3.897m³ ; 1.1 ; 903 kJ]**
31. A rigid container of volume 0.4 m^3 is filled with oxygen until the pressure reaches 1200 kPa. It is then cooled so that the pressure reduces to 900 kPa. How much work is performed ? Draw a p-V diagram for the process.

[0 kJ]

32. A paddle wheel supplies work to a system at the rate of 80 W. During a period of 1 minute the system expands from 0.03 m^3 to 0.08 m^3 against a constant pressure of 500 kPa. Find the net work interaction during this period of 1 minute.

Ans : [20.2 kJ]

33. 1 Kg of air undergoes expansion from 800 kPa, 300 K to 120 kPa in such a way that $p(v + 0.2) = \text{Constant}$, where p is the pressure in kPa and v is the specific volume in m^3/Kg . Find the work done in the process.

Ans : [466.88 kJ]

www.Notesfree.in

Chapter 3

THE FIRST LAW OF THERMODYNAMICS

Energy interactions between a system and its surroundings across the boundary in the form of heat and work have been discussed separately in the previous chapter. So far, no attempt has been made to relate these interactions between themselves and with the energy content of the system.

First law of thermodynamics, often called as law of conservation of energy, relating work, heat, and energy content of the system will be discussed in detail in this chapter.

3.1 First Law of Thermodynamics

In its more general form, the first law may be stated as follows

“When energy is either transferred or transformed, the final total energy present in all forms must precisely equal the original total energy”.

It is based on the experimental observations and can not be proved mathematically. All the observations made so far, confirm the correctness of this law.

3.2 First Law of Thermodynamics for a Closed System Undergoing a Process

First law can be written for a closed system in an equation form as

$$\left[\begin{array}{l} \text{Energy entered} \\ \text{into the system} \end{array} \right] + \left[\begin{array}{l} \text{Energy left} \\ \text{the system} \end{array} \right] = \left[\begin{array}{l} \text{Change in the energy} \\ \text{content of the system} \end{array} \right]$$

For a system of constant mass, energy can enter or leave the system only in two forms namely work and heat.

Let a closed system of initial energy E_1 receives Q units of net heat and gives out W units of work during a process. If E_2 is energy content at the end of the process as given in Figure 3.1, applying first law we get

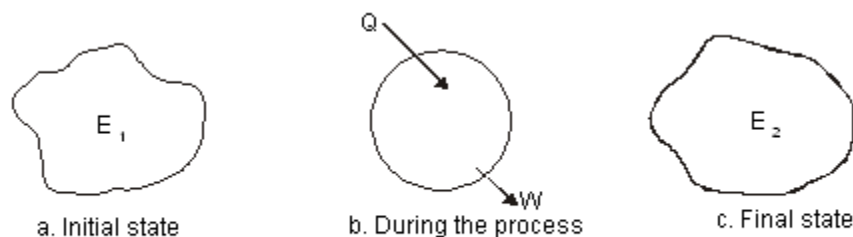

Figure 3.1 First Law for a closed system

$$Q - W = (E_2 - E_1) \quad \dots(3.1)$$

Where the total energy content

$$\begin{aligned} E &= \text{Internal Energy} + \text{Kinetic energy} + \text{Potential energy} \\ &= U + \frac{1}{2} \frac{mC^2}{g_c} + mgz \end{aligned}$$

The term internal energy usually denoted by the letter U is the energy due to such factors as electron spin and vibrations, molecular motion and chemical bond.

Kinetic energy term is due to the system movement with a velocity C. For stationary systems this term will be zero. The term g_c is a constant of value 1 in SI unit. It will be dropped here after since SI unit is followed throughout the book.

Potential energy term is due to the location of the system in the gravitational field. It remains constant for a stationary system. The unit of energy in SI is kJ.

3.3 The Thermodynamic Property Enthalpy

Consider a stationary system of fixed mass undergoing a quasi-equilibrium constant pressure process

Applying first law

$$Q_{12} - {}_1W_2 = E_2 - E_1$$

$$\text{where } E_2 - E_1 = (U_2 - U_1) + m(C_2^2 - C_1^2) + mg(Z_2 - Z_1)$$

$$= U_2 - U_1$$

since it is a stationary system.

$$\text{also } {}_1W_2 = p(V_2 - V_1)$$

$$= p_2V_2 - p_1V_1$$

$$\therefore Q_{12} = (p_2V_2 - p_1V_1) + (U_2 - U_1)$$

$$= (U_2 + p_2V_2) - (U_1 + p_1V_1)$$

The terms within brackets are all properties depending on the end states. This combination of properties may be regarded as a single property known as enthalpy. It is usually denoted by the letter H.

$$\text{ie } H = U + pV \quad \dots(3.3a)$$

$$\text{(or) } h = u + pv \quad \dots(3.3b)$$

Where h is specific enthalpy in kJ/kg

u is specific internal energy in kJ/kg and

v is specific volume in m^3/kg

3.4 Flow Energy

Flow energy is defined as the energy required to move a mass into the a control volume against a pressure. Consider a mass of volume V entering into a control volume as given in the Figure 3.2 against a pressure p .

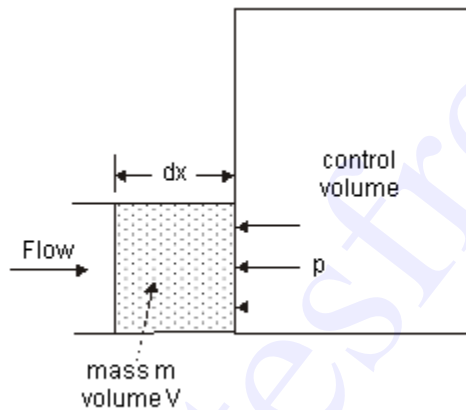

Figure 3.2 Flow energy

$$\begin{aligned}\text{The Flow energy} &= \text{Work done in moving the mass} \\ &= \text{Force} \times \text{distance} \\ &= pA \times dx \\ &= p \times (Adx) \\ &= pV \end{aligned} \quad \dots(3.4)$$

Therefore, Enthalpy = Internal energy + Flow energy

3.5 First Law of Thermodynamics for a Control Volume

Mass simultaneously entering and leaving the system is a very common phenomenon in most of the engineering applications. Control volume concept is applied to these devices by assuming suitable control surfaces.

To analyze these control volume problems, conservation of mass and energy concepts are to be simultaneously considered.

Energy may cross the control surface not only in the form of heat and work but also by total energy associated with the mass crossing the boundaries. Hence apart from kinetic, potential and internal energies, flow energy should also be taken into account.

Conservation of mass

$$\left[\begin{array}{l} \text{Total mass} \\ \text{entering the} \\ \text{control volume} \end{array} \right] + \left[\begin{array}{l} \text{Total mass} \\ \text{leaving the} \\ \text{control volume} \end{array} \right] = \left[\begin{array}{l} \text{Net change in the} \\ \text{mass content of the} \\ \text{control volume} \end{array} \right]$$

Conservation of energy

$$\left[\begin{array}{l} \text{Net energy crossing the} \\ \text{boundary in the} \\ \text{form of heat} \\ \text{and work} \end{array} \right] + \left[\begin{array}{l} \text{Total energy} \\ \text{associated with the} \\ \text{mass entering} \\ \text{the control volume} \end{array} \right] - \left[\begin{array}{l} \text{Total energy} \\ \text{associated with the} \\ \text{mass leaving} \\ \text{the control volume} \end{array} \right] = \left[\begin{array}{l} \text{Net change} \\ \text{in the energy} \\ \text{content of the} \\ \text{control volume} \end{array} \right]$$

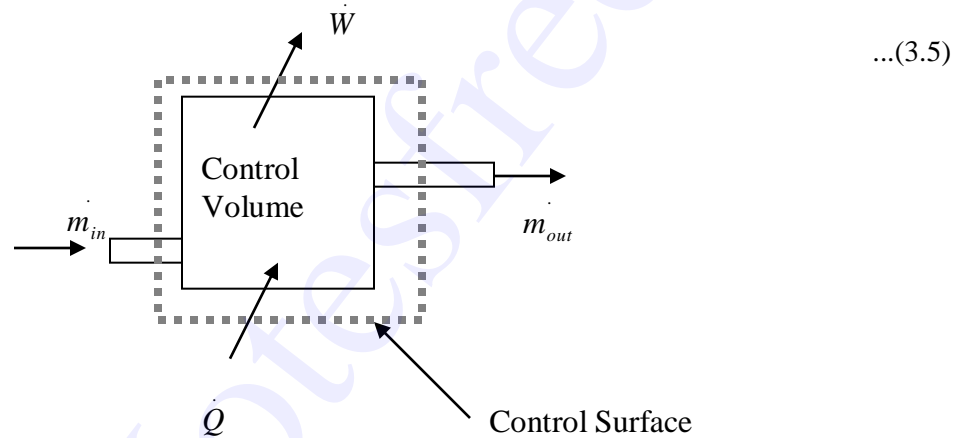

Figure 3.3 First Law of Thermodynamics Applied to a control Volume

As a rate equation, it becomes

$$\left[\dot{Q} - \dot{W} \right] + \sum_{in} \dot{m}_{in} \left[h + \frac{C^2}{2} + Zg \right] - \sum_{out} \dot{m}_{out} \left[h + \frac{C^2}{2} + Zg \right] = \left[\Delta E_{cv} \right] \quad \dots(3.6)$$

3.6 The Steady-state Flow Process

When a flow process is satisfying the following conditions, it is known as a steady flow process.

1. The mass and energy content of the control volume remains constant with time.
2. The state and energy of the fluid at inlet, at the exit and at every point within the control volume are time independent.
3. The rate of energy transfer in the form of work and heat across the control surface is constant with time.

Therefore for a steady flow process

$$\sum m_{in} \stackrel{(3.7)}{=} \sum m_{out} \quad \dots(3.7)$$

also

$$[\Delta E_{CV}] = 0 \quad \dots(3.8)$$

$$[\dot{Q} - \dot{W}] + \sum_{in} m_{in} \left[h + \frac{C^2}{2} + Zg \right] - \sum_{out} m_{out} \left[h + \frac{C^2}{2} + Zg \right] = 0 \quad \dots(3.9)$$

For problem of single inlet stream and single outlet stream

$$[\dot{Q} - \dot{W}] = \dot{m} \left[(h_2 - h_1) + \left(\frac{C_2^2 - C_1^2}{2} \right) + (Z_2 - Z_1)g \right] \quad \dots(3.10)$$

This equation is commonly known as steady flow energy equation (SFEE).

3.7 Application of SFEE

SFEE governs the working of a large number of components used in many engineering practices. In this section a brief analysis of such components working under steady flow conditions are given and the respective governing equations are obtained.

3.7.1. Turbines

Turbines are devices used in hydraulic, steam and gas turbine power plants. As the fluid passes through the turbine, work is done on the blades of the turbine which are attached to a shaft. Due to the work given to the blades, the turbine shaft rotates producing work.

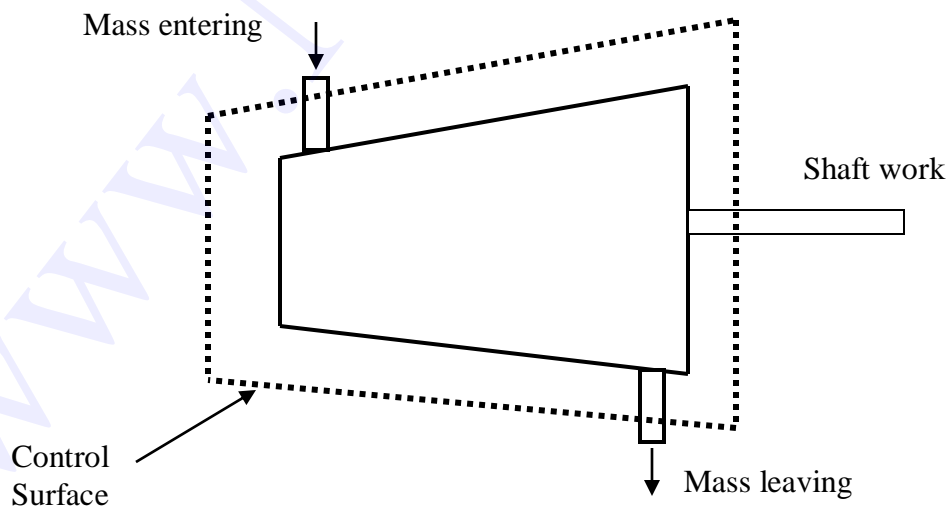

Figure 3.4 Schematic Representation of a Turbine

General Assumptions

1. Changes in kinetic energy of the fluid are negligible
2. Changes in potential energy of the fluid are negligible.

$$[\dot{Q} - \dot{W}] = \dot{m}(h_2 - h_1) \quad \dots(3.11)$$

3.7.2 Compressors

Compressors (fans and blowers) are work consuming devices, where a low-pressure fluid is compressed by utilising mechanical work. Blades attached to the shaft of the turbine imparts kinetic energy to the fluid which is later converted into pressure energy.

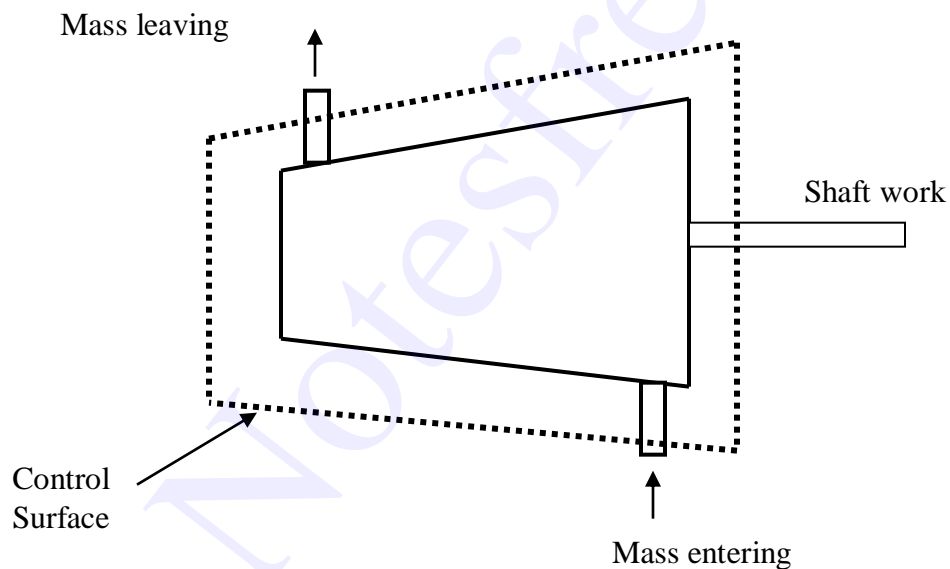

Figure 3.5 Schematic Representation of a Compresso

General Assumptions

1. Changes in the kinetic energy of the fluid are negligible
2. Changes in the potential energy of the fluid are negligible

Governing Equation

Applying the above equations SFEE becomes

$$[\dot{Q} - \dot{W}] = \dot{m}(h_2 - h_1) \quad \dots(3.12)$$

3.7.3 Pumps

Similar to compressors pumps are also work consuming devices. But pumps handle incompressible fluids, whereas compressors deal with compressible fluids.

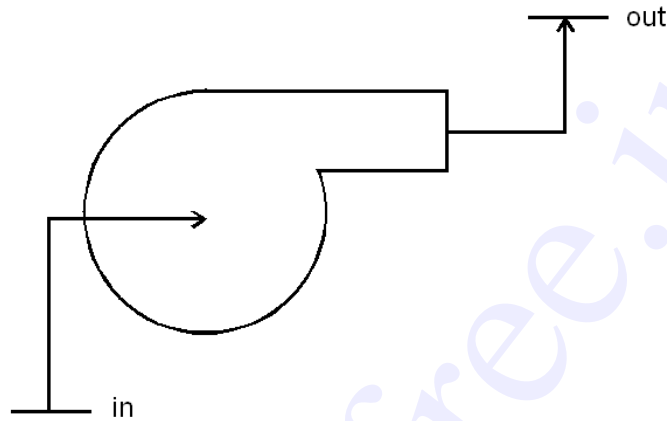

Figure 3.6 Schematic diagram of a pump

General Assumptions

1. No heat energy is gained or lost by the fluids;
2. Changes in kinetic energy of the fluid are negligible.

Governing Equation

$$[-\dot{W}] = \dot{m}[(h_2 - h_1) + (Z_2 - Z_1)g] \quad \dots(3.13)$$

As the fluid passes through a pump, enthalpy of the fluid increases, (internal energy of the fluid remains constant) due to the increase in pv (flow energy). Increase in potential energy of fluid is the most important change found in almost all pump applications.

3.7.4 Nozzles

Nozzles are devices which increase the velocity of a fluid at the expense of pressure. A typical nozzle used for fluid flow at subsonic* speeds is shown in Figure 3.7.

General Assumptions

1. In nozzles fluids flow at a speed which is high enough to neglect heat lost or gained as it crosses the entire length of the nozzle. Therefore, flow through nozzles can be regarded as adiabatic. That is $q = 0$.
2. There is no shaft or any other form of work transfer to the fluid or from the fluid; that is $\dot{W} = 0$.
3. Changes in the potential energy of the fluid are negligible.

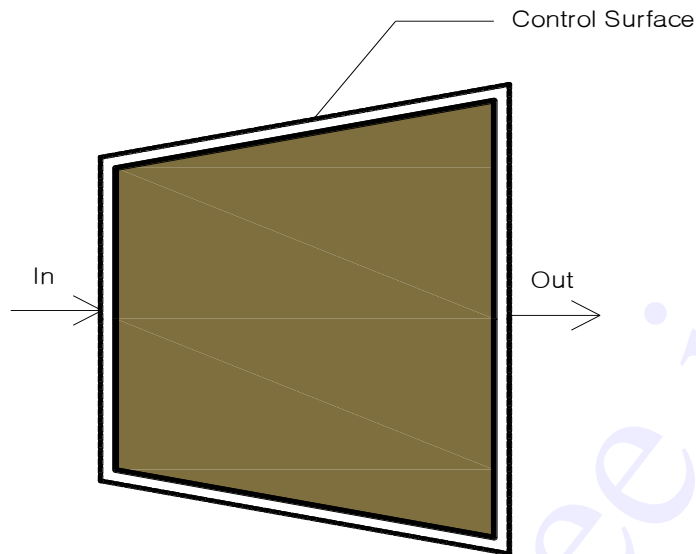

Governing Equation

$$\left[(h_2 - h_1) + \left(\frac{C_2^2 - C_1^2}{2} \right) \right] = 0$$

$$\left(\frac{C_2^2 - C_1^2}{2} \right) = (h_1 - h_2)$$

3.7.5 Diffusers

Diffusers are (reverse of nozzles) devices which increase the pressure of a fluid stream by reducing its kinetic energy.

General Assumptions

Similar to nozzles, the following assumptions hold good for diffusers.

1. Heat lost or gained as it crosses the entire length of the nozzle. Therefore, flow through nozzles can be regarded as adiabatic. That is $\dot{Q} = 0$
2. There is no shaft or any other form of work transfer to the fluid or from the fluid; that is $\dot{W} = 0$.
3. Changes in the potential energy of the fluid are negligible

Governing Equation

...(3.14)

$$\left[(h_2 - h_1) + \left(\frac{C_2^2 - C_1^2}{2} \right) \right] = 0$$
$$(h_2 - h_1) = \left(\frac{C_1^2 - C_2^2}{2} \right)$$

3.7.6 Heat Exchangers

Devices in which heat is transferred from a hot fluid stream to a cold fluid stream are known as heat exchangers.

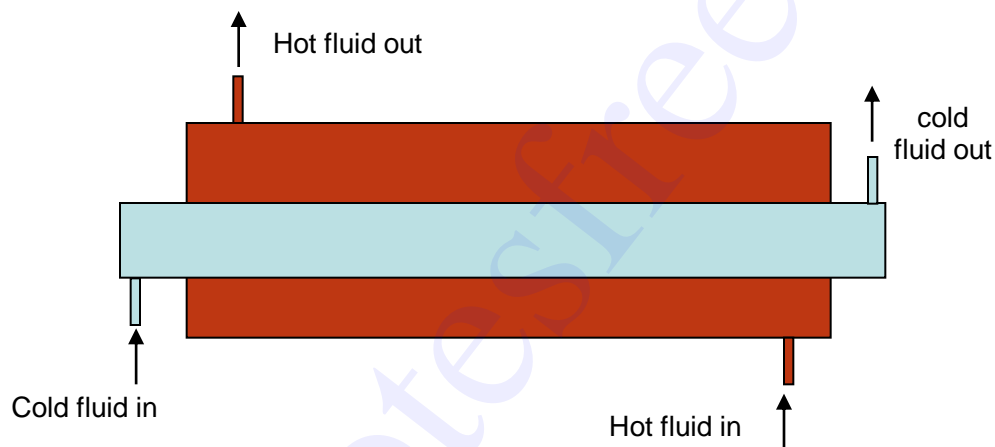

General Assumptions

1. Heat lost by the hot fluid is equal to the heat gained by the cold fluid.
2. No work transfer across the control volume.
3. Changes in kinetic and potential energies of both the streams are negligible.

Governing Equation

For both hot and cold streams

$$[\dot{Q}] = \dot{m}(h_2 - h_1)$$

As per the assumption,

$$-\dot{Q}_{hot} = \dot{Q}_{cold}$$

The negative sign in the LHS is to represent that heat is going out of the system.

$$\dot{m}_h (h_1 - h_2) = \dot{m}_c (h_2 - h_1) \quad \dots(3.15)$$

3.7.7 Throttling

A throttling process occurs when a fluid flowing in a line suddenly encounters a restriction in the flow passage. It may be

- a plate with a small hole as shown in Figure 3.10 (a)
- a valve partially closed as shown in Figure 3.10 (b)
- a capillary tube which is normally found in a refrigerator as shown in Figure 3.10 (c)
- a porous plug as shown in Figure 3.10 (d)

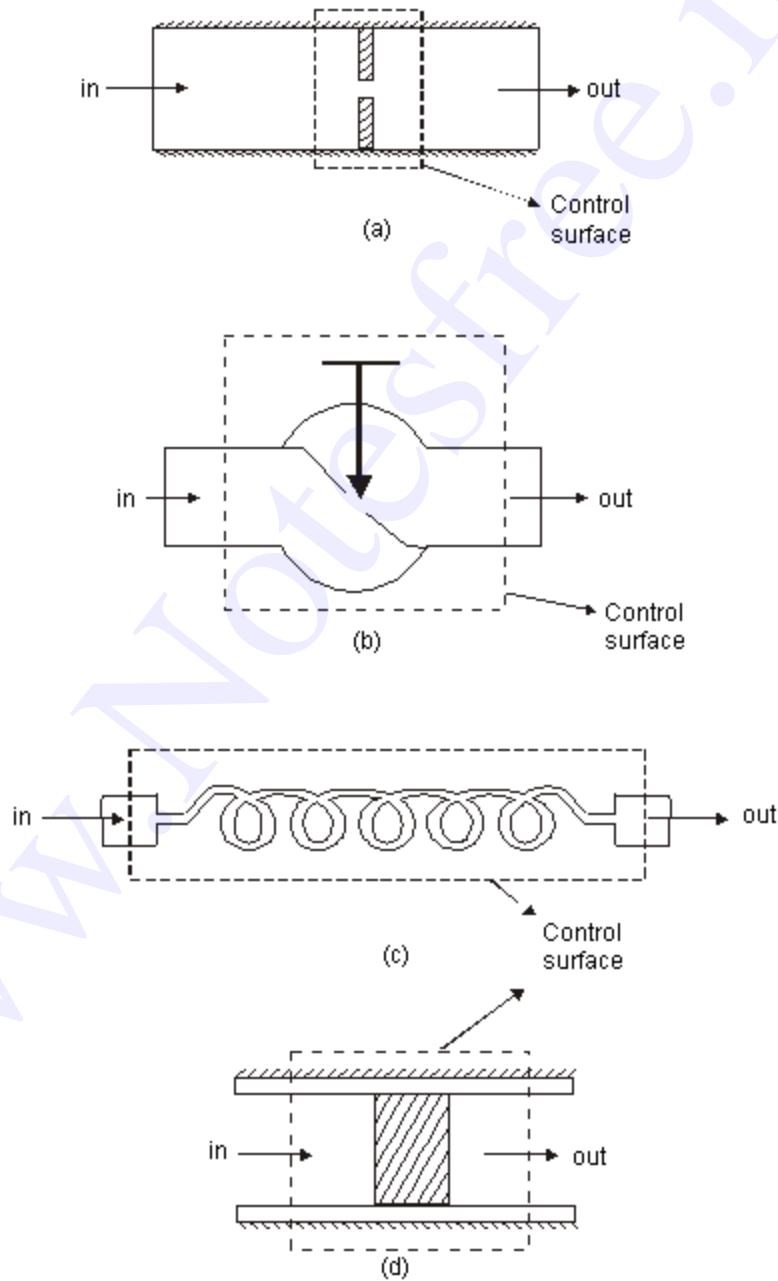

Figure 3.10 Examples of throttling processes

General assumptions

1. No heat energy is gained or lost by the fluid; ie., $Q = 0$
2. There is typically some increase in velocity in a throttle, but both inlet and exit kinetic energies are usually small enough to be neglected.
3. There is no means for doing work; ie., $W = 0$.
4. Changes in potential energy of the fluid is negligible.

Governing Equation

$$h_2 = h_1 \quad \dots(3.16)$$

Therefore, throttling is an **isenthalpic process**.

3.8 First Law for a Cyclic Process

In a cyclic process the system is taken through a series of processes and finally returned to its original state. The end state of a cyclic process is identical with the state of the system at the beginning of the cycle. This is possible if the energy level at the beginning and end of the cyclic process are also the same. In other words, the net energy change in a cyclic process is zero.

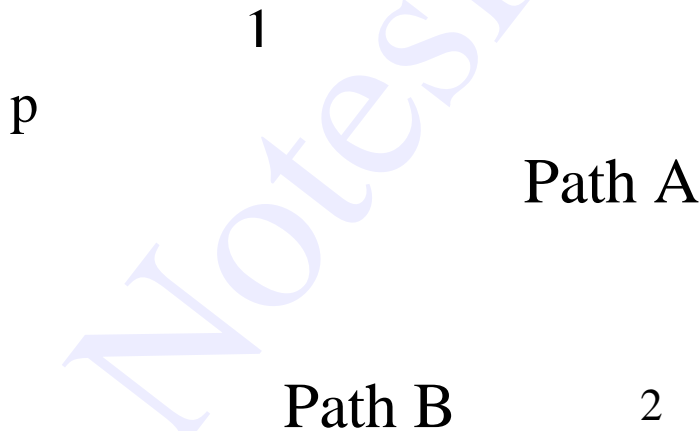

Figure 3.11 First Law for a Cyclic Process

Consider a system undergoing a cycle consisting of two processes A & B as shown in Figure 3.11 Net energy change

$$\Delta E_A + \Delta E_B = 0 \quad \dots(3.17)$$

$$(Q_A - W_A) + (Q_B - W_B) = 0 \quad \dots(3.18)$$

$$\text{ie} \quad Q_A - Q_B = W_A - W_B \quad \dots(3.19)$$

$$\text{(or)} \quad \oint dQ = \oint dW \quad \dots(3.20)$$

Hence for a cyclic process algebraic sum of heat transfers is equal to the algebraic sum of work transfer.

This was first proved by Joule, based on the experiments he conducted between 1843 and 1858, that were the first quantitative analysis of thermodynamic systems.

3.9 Energy is a property of a system

Consider a system undergoing a process from state 1 to state 2 along path A as shown in Figure 3.12. Let the system be taken back to the initial state 1 along two possible paths B and C. Process A, combined separately with process B and C forms two possible cycles.

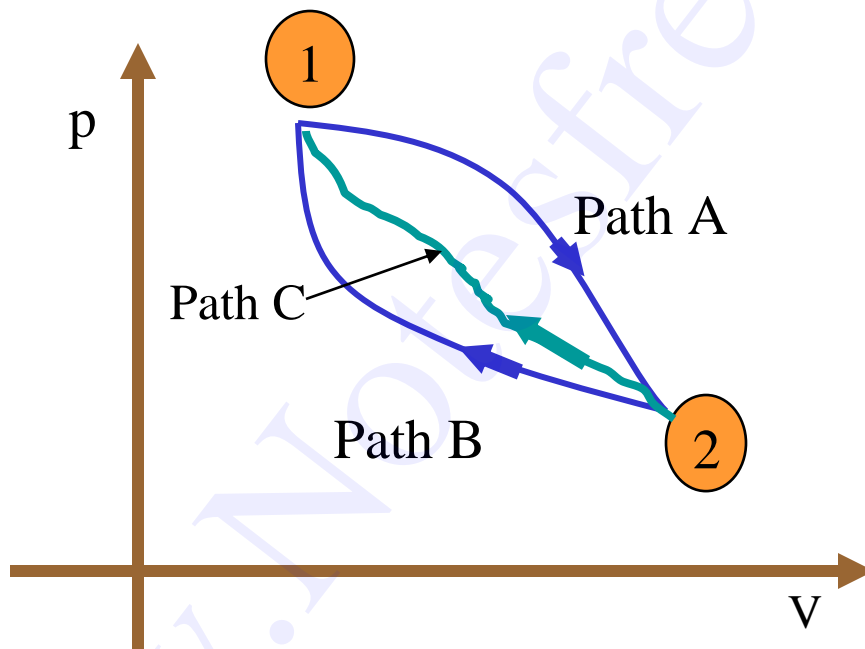

Figure 3.12 Illustration to show that energy is property

Cycle 1A2B1

$$Q_A + Q_B = [W_A + W_B]$$

$$Q_A - W_A = -[Q_B - W_B]$$

$$\Delta E_A = -\Delta E_B \quad \dots(3.21)$$

Cycle 1A2C1

$$Q_A + Q_C = [W_A + W_C]$$

$$Q_A - W_A = -[Q_C - W_C]$$

$$\Delta E_A = -\Delta E_C \quad \dots(3.22)$$

From Equation (3.21) and (3.22) it can be concluded that energy change in path B and path C are equal and hence energy is a point function depending only on the end states.

It has been already shown that all the properties are point functions and hence energy is also a property of the system.

3.10 Specific Heat at Constant Volume and at Constant Pressure

Specific heat at constant volume of a substance is the amount of heat added to rise the temperature of unit mass of the given substance by 1 degree at constant volume

From first law for a stationary closed system undergoing a process

$$dQ = pdV + dU \text{ or } dq = pdv + du$$

For a constant volume process

$$dQ = dU \text{ or } dq = du$$

\therefore

$$\text{or } du = C_v dT \quad \dots(3.23)$$

Similarly specific heat at constant pressure is the quantity of heat added to rise the temperature of unit mass of the given substance by 1 degree at constant pressure

$$\begin{aligned} \text{where } dQ &= pdV + dU \\ &= pdV + d(H - PV) \\ dQ &= pdV + dH - Vdp - pdV \\ dQ &= dH - Vdp \end{aligned}$$

For a constant pressure process $dp = 0$

Hence $dQ = dH$ or $dq = dh$

\therefore

$$\text{or } dh = C_p dT \quad \dots(3.24)$$

Note

- For solids and liquids, constant volume and constant pressure processes are identical and hence, there will be only one specific heat.
- The difference in specific heats $C_p - C_v = R =$
- The ratio of sp. heat $\gamma = C_p/C_v$
- Since h and u are properties of a system, $dh = C_p dT$ and $du = C_v dT$, for all processes.

3.11 Work Interaction in a Reversible Steady Flow Process

In a steady flow process the work interaction per unit mass between an open system and the surroundings can be expressed in differential form as

$$dq - dw = dh + CdC + gdz$$

$$dw = dq - (dh + CdC + gdz)$$

Also, $dq = du + pdv$ (or) $dh - vdp$

Therefore, $dw = dh - vdp - (dh + CdC + gdz)$
 $= -vdp - (CdC + gdz)$

$$W = -\int_1^2 v dp - \left(\frac{C_2^2 - C_1^2}{2} \right) - g(z_2 - z_1)$$

For a stationary system

$$W = -\int_1^2 v dp$$

...(3.26)

3.12 First law for an open system under unsteady flow conditions

Many processes of engineering interest involve unsteady flow, where energy and mass content of the control volume increase or decrease.

Example for such conditions are:

- 1) Filling closed tanks with a gas or liquid.
- 2) Discharge from closed vessels.
- 3) Fluid flow in reciprocating equipments during an individual cycle.

To develop a mathematical model for the analysis of such systems the following assumptions are made.

- 1) The control volume remains constant relative to the coordinate frame.
- 2) The state of the mass within the control volume may change with time, but at any instant of time the state is uniform throughout the entire control volume.
- 3) The state of the mass crossing each of the areas of flow on the control surface is constant with time although the mass flow rates may be time varying.

Unlike in steady flow system, duration of observation Δt plays an important role in transient analysis. Let mass of the working fluid within the control volume before and after the observation be m_1 and m_2 respectively. Applying mass balance we get,

$$(m_2 - m_1)_{cv} = \Sigma m_i - \Sigma m_o \quad \dots(3.27)$$

Where Σm_i is the mass entered the control volume during the interval Δt seconds.

Σm_o is the mass left the control volume during the interval Δt seconds.

By applying energy balance we get,

$$[Q_{cv} - W_{cv}] + \sum_{in} m_{in} \left[h + \frac{C^2}{2} + Zg \right] - \sum_{out} m_{out} \left[h + \frac{C^2}{2} + Zg \right] = \Delta E_{cv} \quad \dots(3.28)$$

Where E_{cv} is the change in energy content of the control volume in Δt seconds.

Q_{cv} is the heat energy entered into the control volume in Δt seconds.

W_{cv} is the work energy left the control volume in Δt seconds.

h_i & h_o are specific enthalpy of the inlet and outlet streams respectively.

$\frac{C^2}{2}$ & Zg are the kinetic energy of the inlet and outlet streams respectively.

$Z_i g$ & $Z_o g$ are the potential energy of inlet and outlet streams respectively.

3.13 Perpetual Motion Machine - I

An engine which could provide work transfer continuously without heat transfer is known as perpetual motion machine of first kind. It is impossible to have such an engine as it violates first law of thermodynamics.

Exercises

1. Define internal energy.
2. Express mathematically first law of thermodynamic for the following.
 - a. a closed system undergoing a process
 - b. a stationary system of fixed mass undergoing a change of state
 - c. a closed system undergoing a cycle.
 - d. an open system.
 - e. an open system with steady-state flow conditions.
3. Define flow energy and enthalpy.
4. For a stationary system of fixed mass undergoing a process such that its volume remains constant,
$$Q_{12} = \Delta U(T/F)$$
5. $dQ = dh - vdp$ for closed system undergoing a process (T/F).
6. Define specific heat at (a) constant pressure (b) constant volume
7. Determine the power of the cycle comprising four processes in which the heat transfers are : 50 kJ/kg, -20 kJ/kg, -71 J/kg and 12 kJ/kg having 100 cycles per minute.

[48.3 kW]
8. Write the steady flow energy equation and explain the terms involved in it.
9. Show that energy is a property of the system.
10. What are conditions for steady flow process?
11. A piston-cylinder assembly contains 1kg of nitrogen at 100 kPa. The initial volume is 0.5 m³. Heat is transferred to the substance in an amount necessary to cause a slow expansion at constant temperature. This process is terminated when the final volume is twice the initial volume.

[34.7 kJ]
12. 2 kg of air enclosed in a rigid container receives 0.2 kJ of paddle wheel work and 0.5 kJ of electrical energy per second. Heat loss from the system is 0.6 kJ/s. If the initial temperature is 25°C what will be the temperature after 5 minutes?

[45.9°C]
13. A well insulated, frictionless piston-cylinder assembly contains 0.5 kg of air initially at 75°C and 300 kPa. An electric - resistance heating element inside the cylinder is energized and causes the air temperature to reach 150°C. The pressure of the air is maintained constant throughout the process. Determine the work for the process and the amount of electrical work.

$$\{\text{Hint } Q_{\text{net}} - W_{\text{net}} = \Delta U; \quad W_{\text{net}} = +W_{\text{electric}}\}$$

[-26.9 kJ ; - 37.7]

14. A cylinder contains 168 litres of a gas at a pressure of 1 bar and temperature of 47°C. If this gas is compressed to one-twelfth of its volume, pressure is then 21 bar. Find
- index of compression
 - change in internal energy
 - heat rejected during compression

Take $C_p = 1.089$ and $C_v = 0.837$ both in kJ/kg

[1.225 ; 41.81 kJ ; -14.05 kJ]

15. **a.** A mass of 10 kg is falling from a height of 100 m from the datum. What will be the velocity when it reaches a height of 20 m from the datum? Take the total heat loss from the mass when it falls from 100 m height to 20 m height is 5 kJ.

[8.68 m/s]

- b.** An insulated box containing carbon dioxide gas falls from a balloon 3.5 km above the earth's surface. Determine the temperature rise of the carbon dioxide when box hits the ground.

Take $C_v = 0.6556$ kJ/kg

[52.37°C]

16. A working substance flows at a rate of 5 kg/s into a steady flow system at 6 bar, 2000 kJ/kg of internal energy and 0.4 m³/kg specific volume with a velocity of 300 m/s. It leaves at 10 bar, 1600 kJ/kg internal energy, 1.2 m³/kg specific volume with a velocity of 150 m/s. The inlet is 10m above the outlet. The work transfer to the surroundings is 3 MW. Estimate the heat transfer and indicate the direction.

[5630 kJ/s]

17. An air compressor takes in air at 100 kPa, 40°C and discharges it at 690 kPa, 208°C. The initial and final internal energy values for the air are 224 and 346 kJ/kg respectively. The cooling water around the cylinders removes 70 kJ/kg from the air. Neglecting changes in kinetic and potential energy, calculate the work.

[100.216 kJ/kg]

18. A perfect gas of $c_p = 1.1$ kJ/kg flows through a turbine at a rate of 3 kg/s. The inlet and exit velocity are 30 and 130 m/s respectively. The initial and final temperature are 650°C and 250°C respectively. Heat loss is 45 kJ/s. Find the power developed.

[1251 kW]

19. In a turbine 4500 kg/min of air expands polytropically from 425 kPa and 1360 K to 101 kPa. The exponent n is equal to 1.45 for the process. Find the work and heat.

[33939 kW ; -2927 kJ/s]

20. Air expands through a nozzle from a pressure of 500 kPa to a final pressure of 100 kPa. The enthalpy decrease by 100 kJ/kg. The flow is adiabatic and the inlet velocity is very low. Calculate the exit velocity.

[447.2 m/s]

21. A closed system undergoes a cycle consisting of three process 1-2, 2-3 and 3-1. Given that $Q_{12} = 30$ kJ, $Q_{23} = 10$ kJ, ${}_1w_2 = 5$ kJ, ${}_3w_2 = 5$ kJ and $\Delta E_{31} = 15$ kJ, determine Q_{31} , w_{23} , ΔE_{12} and ΔE_{23} .

[20 kJ ; 50 kJ ; 25 kJ ; -40 kJ]

22. The following cycle involves 3 kg of air : Polytropic compression from 1 to 2 where $P_1 = 150$ kPa, $T_1 = 360$ K, $P_2 = 750$ kPa and $n = 1.1$; constant-pressure cooling from 2 to 3; and constant - temperature heating from 3 to 1. Draw the pV diagram and find temperatures, pressures and volumes at each state and determine the net work and heat.

[150 kPa ; 2.066 m³; 360 K ; 750 kPa ; 0.478 m³ ;
416.72 K ; 750 kPa ; 0.414 m³ ; 360 K ; -35 kJ]

23. A cycle, composed of three processes, is :

Polytropic compression ($n = 1.5$) from 137 kPa and 38°C to state 2 ; constant pressure process from state 2 to state 3 ; constant volume process from state 3 and to state 1. The heat rejected in process 3-1 is 1560 kJ/kg and the substance is air. Determine

- the pressures, temperatures and specific volumes around the cycle
- the heat transfer in process 1-2
- the heat transfer in process 2-3
- work done in each process and
- net work done in the cycle

[137 kPa ; 0.6515 m³/kg ; 311.0 K ; 1095 kPa ; 0.1630 m³/kg ;
621.8 K ; 1095 kPa ; 0.6515 m³/kg ; 2487.0 K ; 44.44 kJ ;
1872.25 kJ ; -178 kJ ; 534.9 kJ ; 0 ; 356.9 kJ]

24. 0.15 m³ of air at a pressure of 900 kPa and 300° C is expanded at constant pressure to 3 time its initial volume. It is then expanded polytropically following the law $PV^{1.5} = C$ and finally compressed back to initial state isothermally. Calculate

- heat received
- heat rejected
- efficiency of the cycle

[944.5kJ ; -224.906 kJ ; 0.291]

25. A piston and cylinder device contains 1 kg of air, Initially, $v = 0.8$ m³/kg and $T = 298$ K. The air is compressed in a slow frictionless process to a specific volume of 0.2 m³/kg and a temperature of 580 K according to the equation $pV^{1.3} = 0.75$ (p in bar, v in m³/kg). If C_v of air is 0.78 kJ/kg determine :

- (a) work and
 (b) heat transfer (both in kJ)

[-137.85 kJ ; 82.11 kJ]

26. The internal energy of a closed system is given by $U = 100 + 50 T + 0.04 T^2$ in Joules, and the heat absorbed by $Q = 4000 + 16 T$ in Joules, where T is in Kelvin. If the system changes from 500 K to 1000 K, what is the work done ?

[47 kJ]

27. One kg of air, volume 0.05 m^3 , pressure 20 bar expands reversibly according to the law $p v^{1.3} = C$ until the volume is doubled. It is then cooled at constant pressure to initial volume and further heat at constant volume so that it returns back to initial process. Calculate the network done by air.

[21.98 kJ]

28. Air at the rate of 14 kg/s expands from 3 bar, 150°C to 1bar reversibly and adiabatically. Find the exit temperature and power developed. Neglect the changes in kinetic and potential energy. [309 k ; 1.603 kW]

29. Specific internal energy of a certain substance can be expressed as follows:

$$u = 831.0 + 0.617 pv$$

Where u is the specific internal energy in kJ/kg

p is the pressure in k Pa

v is the specific volume in m^3/kg

One kg of such substance expands from 850 kPa, $0.25 \text{ m}^3/\text{kg}$ to 600 kPa, $0.5 \text{ m}^3/\text{kg}$. Find the work done and heat transferred. [176.06 kJ ; 230 kJ]

30. A cylinder of 8 cm internal diameter is fitted with a piston loaded by a coil spring of stiffness 140 N/cm of compression. The cylinder contains 0.0005 m^3 of air at 15°C and 3 bar. Find the amount of heat which must be supplied for the piston to a distance of 4 cm. Sketch the process on a p - V diagram.

[0.417 kJ]

31. Prove that
 $Q = mC_v$
 for a polytropic process of index n .

32. An air conditioning system for a computer room in a tower block draws in air on the roof at a height of 100 m with a velocity of 25 m/s. The air is at 28°C . The air is discharged at a height of 10 m with a velocity of 2 m/s at 14°C . The mass flow rate is 2 kg/s, and a heat transfer of -40.73 kW cools the air before it is discharged. Calculate the rate of work for the air passing through the system. Take C_p for air as 1005 J/kgK .

[- 10.23 kW]

33. A diffuser reduces the velocity of an air stream from 300 m/s to 30 m/s. If the inlet pressure and temperature are 1.01 bar and 315°C , determine the outlet pressure. Find also the area required for the diffuser to pass a mass flow of 9 kg/s.

[4.586 bar, 0.17 m²]

34. A centrifugal air compressor operating at steady state has an air intake of 1.2 kg/min. Inlet and exit conditions are as follows:

Properties	p (kPa)	T°C	u kJ/kg	v m ³ /kg
Inlet	100	0	195.14	0.784
Exit	200	50	230.99	0.464

If the heat loss is negligible, find the power input.

[1.005 kW]

35. A household gas cylinder initially evacuated is filled by 15 kg gas supply of enthalpy 625 kJ/kg. After filling, the gas in the cylinder has the following parameters :

pressure = 10 bar ;
enthalpy = 750 kJ/kg and
specific volume = 0.0487 m³/kg.

Evaluate the heat received by the cylinder from the surroundings.

[1144.5 kJ]

36. 0.56 m³ of air at 0.2 MPa is contained in a fully insulated rigid vessel. The vessel communicates through a valve with a pipe line carrying high pressure air at 300 K temperature. The valve is opened and the air is allowed to flow into the tank until the pressure of air in the tank is raised to 1MPa. Determine the mass of air that enters the tank. Neglect kinetic energy of the incoming air.

[3.72 kg]

37. An insulated rigid tank contains 8 kg of air at 1.5 bar pressure and 310 K temperature. It is filled with air from a large reservoir at 15 bar and 335 K. If the air behaves as a perfect gas, make calculations for the amount of air added and its temperature.

[47.6 kg ; 446.04K]

38. A pressure vessel contains a gas at an initial pressure of 3.5 MN/m² and at a temperature of 60°C. It is connected through a valve to a vertical cylinder in which there is a piston. The valve is opened, gas enters the vertical cylinder, and work is done in lifting the piston. The valve is closed and the pressure and the temperature of the remaining gas in the cylinder are 1.7 MN/m² and 25°C, respectively. Determine the temperature of the gas in the vertical cylinder if the process is assumed to be adiabatic. Take $\gamma = 1.4$.

[267.6 K]

39. A pressure vessel is connected, via a valve, to a gas main in which a gas is maintained at a constant pressure and temperature of 1.4 MN/m² and 85°C, respectively. The pressure vessel is initially evacuated. The valve is opened and a mass of 2.7 kg of gas passes into the pressure vessel. The valve is closed and the pressure and temperature of the gas in the pressure vessel are then 700 KN/m² and 60°C, respectively. Determine the heat transfer to or from the gas in the vessel. Determine the volume of the vessel and the volume of the gas before transfer.

For the gas, take $C_p = 0.88$ kJ/kgK, $C_v = 0.67$. Neglect velocity of the gas in the main

[-248.2 kJ ; 0.27 m³ ; 0.145 m³]

Chapter 4

THE SECOND LAW OF THERMODYNAMICS

4.1 Limitations of First Law of Thermodynamics

If a well insulated tank of fluid is stirred by a rotating paddle wheel, the energy of the fluid increases. If the stirrer is stopped, however the energy of the fluid will not decrease and cause the stirrer to rotate in the opposite direction. The possibility of this process proceeding in the opposite direction is not excluded by the first law of Thermodynamics. *Hence first law of thermodynamics does not allow us to predict whether a proposed conceived energy conversion is possible or not.*

In all the internal combustion engines fuel and air mixture is supplied at room temperature. This mixture undergoes combustion inside the engine and gives out work. Exhaust gases coming out of the engine are always at higher temperature, indicating that some heat is taken away into atmosphere. Hence, in all the IC engines only a part of the heat is converted into work. From our experience we know that if any attempt is made to convert all the heat into work, our effort will go in vain. *This limitation in the extent of energy conversion has also not been addressed in first law of thermodynamics.*

4.2 The Second law of Thermodynamics

Kelvin Planck's statement : *It is impossible to construct a device that, operating continuously, will produce no effect other than transfer of heat from a single thermal reservoir and performance of an equal amount of work.*

The term thermal reservoir refers to a very large system in stable equilibrium, to which or from which, any amount of heat can be transferred at constant temperature.

A thermal reservoir supplying heat continuously at constant temperature is known as source. (Example : Sun)

A thermal reservoir receiving heat continuously at constant temperature is known as sink. (Examples : River, Sea)

From Kelvin-Planck statement it is clear that for any system to operate in a cycle and to give out work continuously it should interact with a minimum of two reservoirs at different temperatures. The system will receive heat from the high temperature reservoir and reject heat to the low temperature reservoir. Such devices are known as heat engines. Performance (or) Efficiency of a heat engine can be expressed as the ratio of desired output to the required input. In a heat engine the desired output is net work output and the required input is total heat input

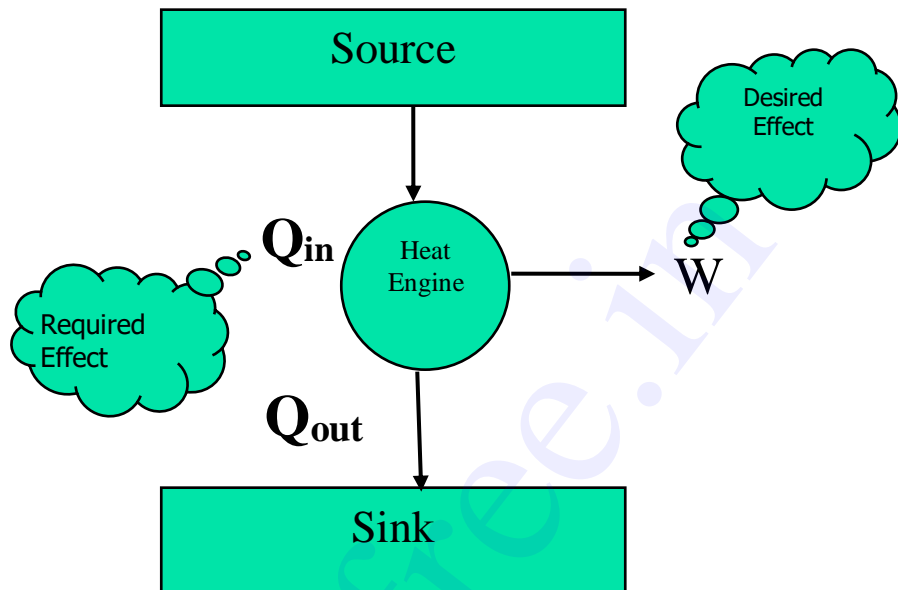

Figure 4.1 Heat Engine

$$\eta = \frac{W_{net}}{Q_{in}}$$

...(4.1)

From first law of thermodynamics

$$\Sigma Q = \Sigma W$$

$$Q_{in} - Q_{out} = W_{net}$$

...(4.2)

Clausius statement : *Unaided by an external agency heat can not be transferred from a body at lower temperature to a body at higher temperature.*

Devices that are used to transfer heat from a body at lower temperature to a body at higher temperature are known as refrigerators (or) heat pumps. If the high temperature side is atmosphere it is a refrigerator. If the low temperature side is atmosphere it is known as a heat pump. The performance index here is called coefficient of performance (COP). In refrigerator (and heat pumps) the performance is the ratio of two independent parameters and hence the possibility of getting the value more than unity is always there. But the term efficiency is restricted to a maximum of unity. Hence the term efficiency is not used here.

$$COP = \frac{\text{Desired Effect}}{\text{Required Effect}}$$

$$COP = \frac{Q_2}{W}$$

Taking work as external agency, for refrigerators (Figure 4.2)

...(4.3)

From first law

$$\Sigma Q = \Sigma W$$

$$Q_1 - Q_2 = W$$

$$COP = \frac{Q_2}{Q_1 - Q_2}$$

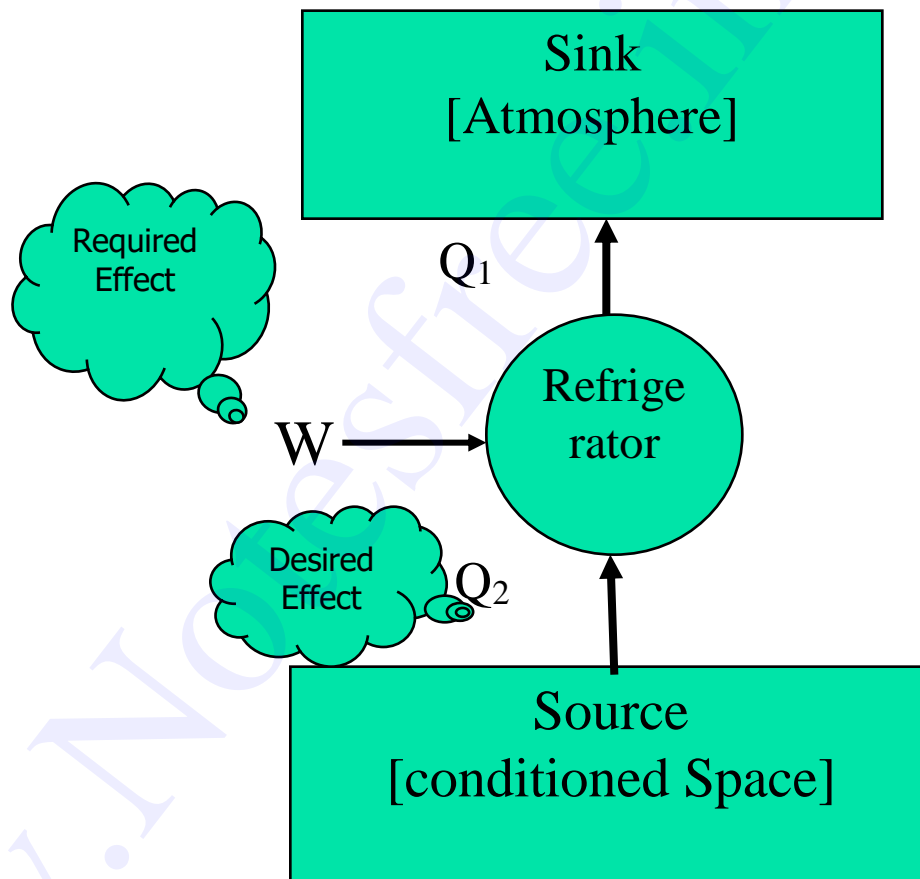

Figure 4.2 Refrigerator

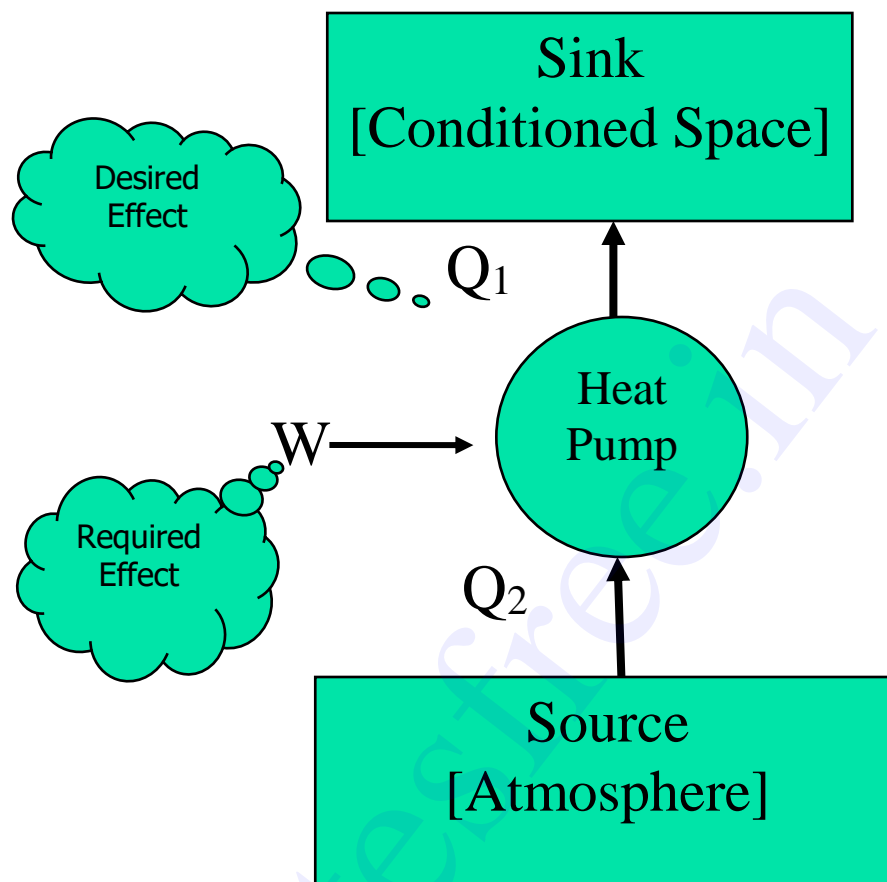

Figure 4.3 Heat Pump

Similarly for a heat pumps (Figure 4.3)

$$COP = \frac{\text{Desired Effect}}{\text{Required Effect}}$$

$$COP = \frac{Q_1}{W} \quad \dots(4.4)$$

Since, $Q_1 + Q_2 = W$

$$COP = \frac{Q_1}{Q_1 - Q_2} \quad \dots(4.5)$$

4.3 Equivalence of Kelvin-Planck and Clausius Statements

The Clausius and Kelvin-Planck statements of the second law are entirely equivalent. This equivalence can be demonstrated by showing that the violation of either statement can result in violation of the other one.

Referring to Figure 4.4(a) the device marked Clausius violator is pumping Q_1 amount of heat from a low temperature reservoir at T_1 to a high temperature reservoir at T_2 without the aid of any external agency. This is an impossible arrangement.

If such an arrangement is possible it would also violate Kelvin-Planck statement. Let a heat engine operating between the same reservoirs at T_2 and T_1 take in Q_2 as heat input at T_2 . It converts a part of this heat into work and rejects heat Q_3 to the sink at T_1 . Since the Clausius violator is rejecting the same quantity Q_2 at T_2 , it can be supplied directly into the heat engine so that the reservoir at T_2 can be eliminated. This combination as shown in Figure 4.4 (b) is producing continuous work with a single reservoir at T_1 . Hence it violates the Kelvin-Planck statement.

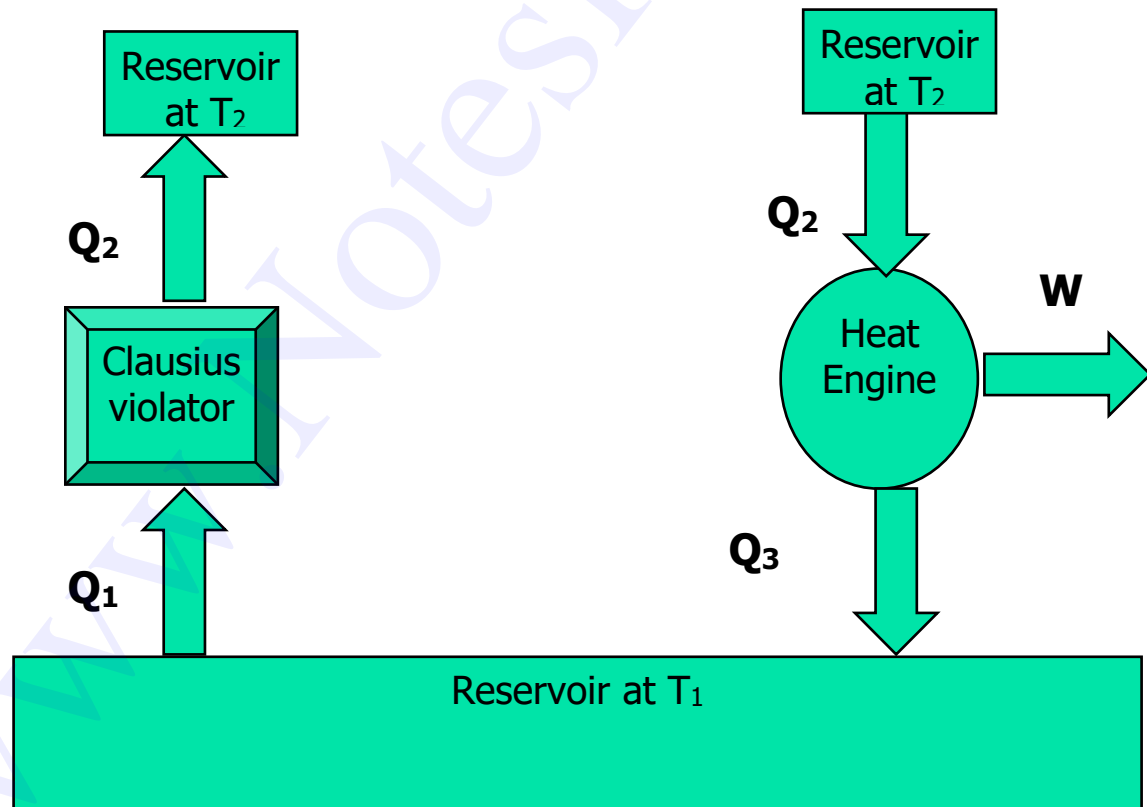

(a)

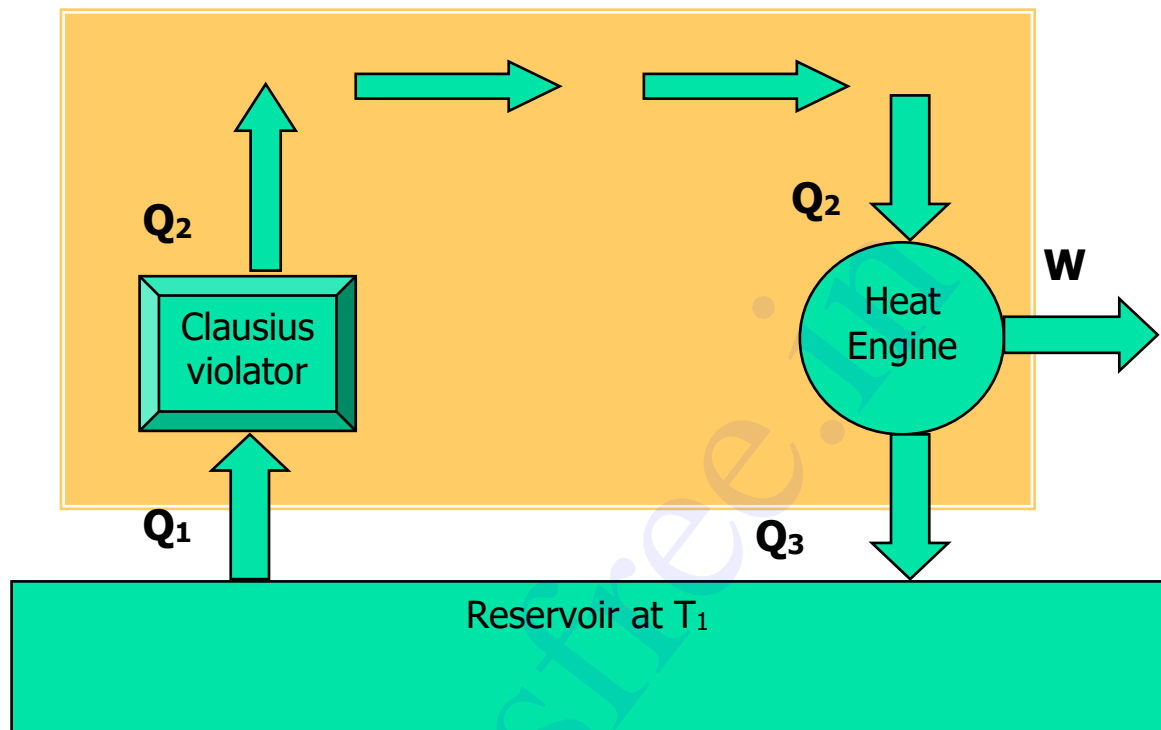

(b)

Figure 4.4 Illustration of the equivalence of Clausius and Kelvin-Planck's statement

Referring to Figure 4.5 a Kelvin-planck violator is converting all heat Q_H taken from the reservoir at T_H into work. If such an impossible heat engine is assumed to exist it will violate the Clausius statement. Consider a refrigerator pumping Q_L heat from the low temperature reservoir at T_L to the reservoir at higher temperature T_H . Combined with the Kelvin-Planck violator, the arrangement is pumping Q_L heat from T_L to T_H , without any external agency. Hence it violate the Clausius statement.

4.4 Reversible Process

A process is said to be reversible if it can be reversed without leaving any trace on the surroundings.

For example, let a system be taken from state 1 to state 2 with a work transfer of +5 kJ and heat transfer of -10 kJ. If the process is reversible, while taking the system from state 2 to state 1, the work transfer must be -5 kJ and heat transfer must be +10 kJ. So that, both the system and surroundings are returned to their initial states at the end of the process 2 to 1.

4.5 Irreversibility and Causes of Irreversibility

The factors that make a process irreversible are known as irreversibilities. Various forms of irreversibilities are listed below.

a) Friction : Friction occurs at the interface of two bodies moving relative to each other. It is the main cause of irreversibility in many processes. Energy spent in overcoming friction is dissipated in the form of heat which can never be restored.

b) Heat transfer: Once heat is transferred from a body at higher temperature to a body at lower temperature, it can never be reversed without the aid of an external agency.

**through finite
temperature
difference**

c) Unresisted expansion :

Consider a vessel with two chambers as given in the arrangement as shown in Fig. 4.6. If the members separating the gas from vacuum is removed, gas will expand and occupy the entire space. Since the expansion has no influence on the surroundings, there is no work output in this process. But to restore the initial arrangement, a definite work input is required.

d) Mixing of two gases : Consider a vessel with two chambers, one with O_2 and the other with N_2 . When the member separating O_2 & N_2 is removed, uniform mixing is taking place without any work output. But such a process can not be reversed without any work input.

e) Throttling : It is a totally irreversible process. Gas or vapour will expand through a restricted passage with its pressure decreasing rapidly without any work output. Such an expansion can not be reversed.

4.6 Externally and internally reversible processes

As mentioned earlier if no irreversibilities occur outside the system boundaries during the process, it is known as externally reversible.

If no irreversibilities occur within the boundary of the system during a process, it is known as internally reversible process. For such a process, the path of the reverse process will follow exactly that of the forward process in any property diagram.

To be totally reversible or simply reversible both external and internal reversibilities must be ensured.

4.7 The Carnot Cycle

In 1824, Nicholas Sadi Carnot proposed a classical ideal cycle consisting of four processes. All processes are individually reversible and hence the cycle as a whole is a reversible cycle. The processes that make up the Carnot cycle are :

Process 1-2

The working substance is taken in a piston cylinder arrangement as given in Figure 4.8(a). Heat is added reversibly and isothermally from a high temperature reservoir at T_H . Since the process is to be reversible, the temperature T_H of the reservoir should be equal to or infinitesimally greater than that of the working substance.

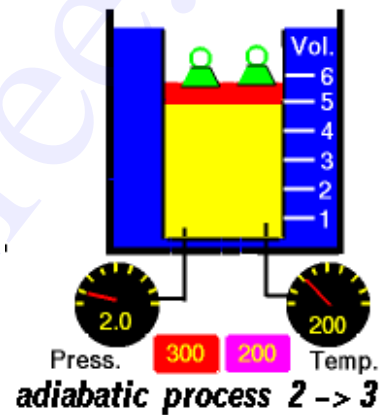
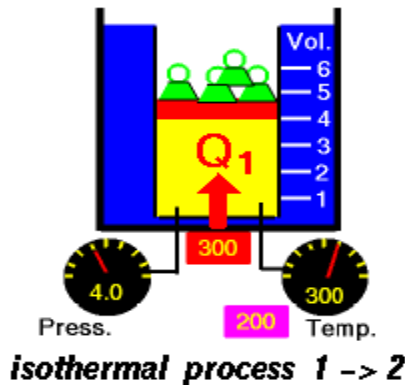

Figure 4.8(a)

Figure 4.8(b)

Process 2-3

The working substance is allowed to expand reversibly and adiabatically until its temperature falls down to T_L . The process is represented by Figure 4.8(b)

Process 3-4

Heat is rejected by the working substance to a low temperature reservoir kept T_L or at temperature infinitesimally smaller than T_L .

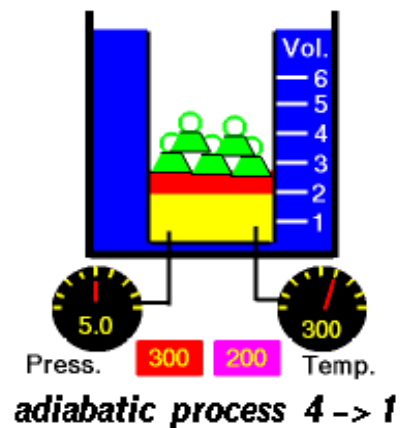
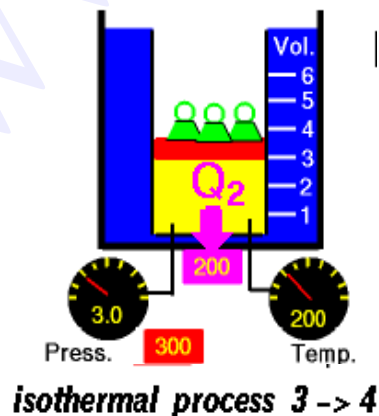

Process 4-1

The working substance is then compressed reversibly and adiabatically until its temperature becomes T_H and the cycle continues.

The cycle has been represented in a p-V diagram in Figure 4.9. The included area represents the net work done in the cycle. From first law of thermodynamics net workdone is equal to net heat transfer in the cycle. Since Q_H is the heat added to system and Q_L is the heat rejected by the system, the net heat transfer is $Q_H - Q_L$.

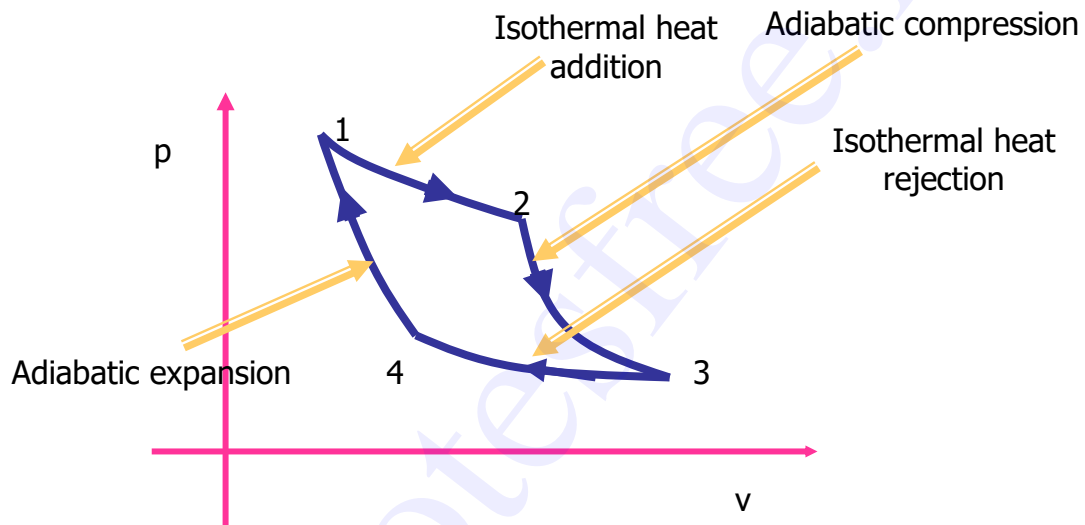

$$\begin{aligned} \text{Efficiency of Carnot Engine} &= \frac{W_{net}}{Q_{in}} \\ &= \frac{Q_H - Q_L}{Q_H} \\ &= 1 - \frac{Q_L}{Q_H} \end{aligned}$$

Where

$$Q_L = W_4 + U_4 - U_3$$

Since the process is isothermal $U_4 = U_3$

$$\therefore Q_L = W_4$$

$$= P_3 V_3 \ln \left[\frac{P_3}{P_4} \right]$$

$$= mRT_L \ln \left[\frac{P_3}{P_4} \right]$$

Similarly $Q_H = mRT_H \ln \left[\frac{P_2}{P_1} \right]$

Process 2-3 is reversible adiabatic

$$\frac{T_2}{T_3} = \left[\frac{P_2}{P_3} \right]^{\left(\frac{\gamma-1}{\gamma} \right)} = \frac{T_H}{T_L}$$

∴

Process 4-1 is also reversible adiabatic

$$\therefore \frac{T_1}{T_4} = \left[\frac{P_1}{P_4} \right]^{\left(\frac{\gamma-1}{\gamma} \right)} = \frac{T_H}{T_L}$$

From the above two expressions

$$\frac{P_2}{P_3} = \frac{P_1}{P_4}$$

$$\frac{P_2}{P_1} = \frac{P_3}{P_4}$$

Substituting the above condition we get

$$\eta_{Carnot} = 1 - \frac{Q_L}{Q_{in}} = 1 - \frac{mRT_L \ln \left(\frac{P_3}{P_4} \right)}{mRT_H \ln \left(\frac{P_2}{P_1} \right)}$$

$$= 1 - \frac{T_L}{T_H}$$

It shows that efficiency of carnot engine is purely a function of T_H and T_L .

Since the carnot cycle being completely reversible, if carried out in reverse direction, the magnitudes of all energy transfers remain the same but their sign change. This reversed carnot

cycle can be applied for a refrigerator or a heat pump. Figure 4.10 shows the p-V diagram of a reversed carnot cycle.

www.Notesfree.in

Chapter 5

ENTROPY

The first law of thermodynamics deals with the property energy and the conservation of energy. The second law introduced in the previous chapter, leads to the definition of a new property called entropy. Entropy is defined in terms of a calculus operation, and no direct physical picture of it can be given. In this chapter, Clausius inequality, which forms the basis for the definition of entropy will be discussed first. It will be followed by the discussion of entropy changes that take place during various processes for different working fluids. Finally, the reversible steady-flow work and the isentropic efficiencies of various engineering devices such as turbine and compressors will be discussed.

5.1 The Clausius Inequality

Consider two heat engines operating between two reservoirs kept at temperature T_H and T_L as shown in the Figure 5.1. Of the two heat engines, one is reversible and the other is irreversible.

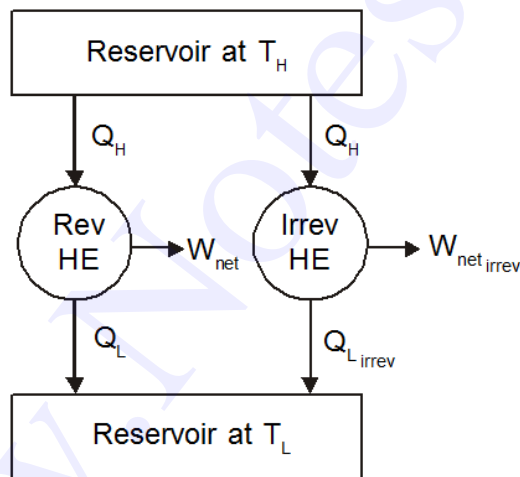

For the reversible heat engine it has already been proved that

$$\frac{Q_H}{Q_L} = \frac{T_H}{T_L}$$
$$\frac{Q_H}{T_H} - \frac{Q_L}{T_L} = 0$$
$$\oint \left(\frac{dQ}{T} \right)_{rev} = 0$$

As discussed earlier, the work output from the irreversible engine should be less than that of the reversible engine for the same heat input Q_H . Therefore $Q_{L, Irrev}$ will be greater than $Q_{L, Rev}$. Let us define

$$Q_{L, Irrev} = Q_{L, Rev} + dQ$$

then

$$\begin{aligned} \oint \left(\frac{dQ}{T} \right)_{Irrev} &= \frac{Q_H}{T_H} - \frac{Q_{L, Irrev}}{T_L} \\ &= \frac{Q_H}{T_H} - \frac{Q_{L, rev}}{T_L} - \frac{dQ}{T_L} \\ &= 0 - \frac{dQ}{T_L} \\ &< 0 \end{aligned}$$

By combining this result with that of a reversible engine we get

$$\oint \left(\frac{dQ}{T} \right)_{Irrev} \leq 0 \quad \dots (5.1)$$

This is known as *Clausius inequality*.

5.2 Entropy

Clausius inequality forms the basis for the definition of a new property known as entropy.

Consider a system taken from state 1 to state 2 along a reversible path A as shown in Figure 5.2. Let the system be brought back to the initial state 1 from state 2 along a reversible path B. Now the system has completed one cycle. Applying Clausius inequality we get

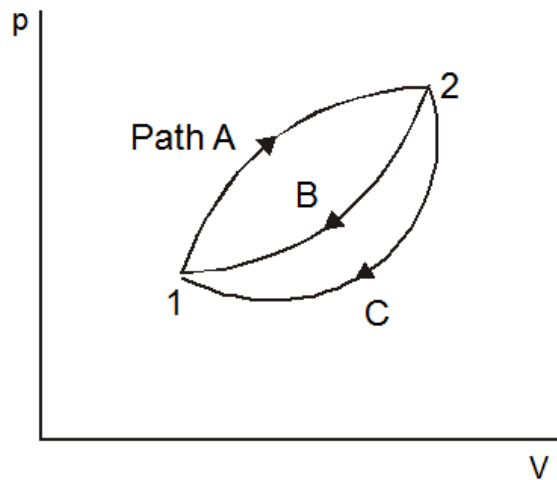

$$\oint \frac{dQ}{T} = 0$$

$$\int_1^2 \left(\frac{dQ}{T} \right)_A + \int_2^1 \left(\frac{dQ}{T} \right)_B = 0$$

...(5.2)

Instead of taking the system from state 2 to state 1 along B, consider another reversible path C. Then for this cycle 1-A-2-C-1, applying Clausius inequality :

$$\oint \frac{dQ}{T} = 0$$

$$\int_1^2 \left(\frac{dQ}{T} \right)_A + \int_2^1 \left(\frac{dQ}{T} \right)_C = 0$$

...(5.3)

Comparing 5.2 & 5.3

Hence, it can be concluded that the quantity is a point function, independent of the path followed. Therefore it is a property of the system. Using the symbol S for entropy we can write

...(5.4)

upon integration we get

$$S_2 - S_1 = \dots \quad (5.5)$$

For a reversible process.

5.3 Entropy change for an irreversible process

The relationship between the entropy change and heat transfer across the boundary during an irreversible processes can be illustrated with a simple cycle composed of two processes, one of which is internally reversible and the other is irreversible, as shown in Figure 5.3. The Clausius inequality applied to this irreversible cycle can be written as

Since the process B is internally reversible, this process can be reversed, and therefore

or

...(5.6)

As defined in equation 5.5, since the process B being reversible the integral on the left hand side can be expressed as

...(5.7)

5.4 Temperature - Entropy diagram

In a T-s diagram consider a strip of thickness ds with mean height T as shown in Figure 5.4. Then Tds gives the area of the strip.

For a reversible process the elemental heat transfer

$$dQ = Tds = \text{Area of the strip}$$

To get the total heat transfer the above equation should be integrated between the limits 1 and 2, so that, we get

...(5.8)

This is equivalent to the area under a curve representing the process in a T-S diagram as shown in the Fig 5.4.

- Note:**
- For an isothermal process $S_2 - S_1 = \dots$
 - For reversible adiabatic process $S_2 - S_1 = 0$.

5.5 Change in Entropy

a) Solids and Liquids

Change in entropy

$$\text{Where } dq = du + pdv$$

For solids and liquids

$$pdv = 0$$

Where c is the specific heat

...(5.9)

b) For ideal gases change in entropy

Substituting

$$du = C_v dT$$

We get

Upon integration

...(5.10a)

Also

Substituting $dh = C_p dT$

and
We get

Upon integration

...(5.10b)

5.6 Principle of Increase in Entropy

Applying Clausius inequality,

For an isolated system undergoing a process

...(5.11)

Consider a system interacting with its surroundings. Let the system and its surroundings are included in a boundary forming an isolated system. Since all the reactions are taking place within the combined system, we can express

or ... (5.12)

Whenever a process occurs entropy of the universe (System plus surroundings) will increase if it is irreversible and remain constant if it is reversible. Since all the processes in practice are irreversible, entropy of universe always increases

ie., $(\Delta S)_{\text{universe}} > 0$... (5.13)

This is known as principle of increase of entropy.

5.7 Adiabatic Efficiency of Compressors and Turbines

In steady flow compressors and turbines reversible adiabatic process is assumed to be the ideal process. But due to the irreversibilities caused by friction between the flowing fluid and impellers, the process is not reversible though it is adiabatic. Percentage deviation of this process from the ideal process is expressed in terms of adiabatic efficiency.

(a) Compressors :

Since compressors are work consuming devices actual work required is more than ideal work.

...(5.14)

For compressors handling ideal gases

...(5.15)

(b) Turbines :

In turbine due to irreversibilities the actual work output is less than the isentropic work.

...(5.16)

For turbines handling ideal gases

...(5.17)

Solved Problems

Prob : 5.1 A body at 200°C undergoes an reversible isothermal process. The heat energy removed in the process is 7875 J. Determine the change in the entropy of the body.

System : Closed system

Known : $T_1 = T_2$
 = 200°C
 = 473 K
 $Q_{\text{rejected}} = 7875 \text{ J}$

Process : Isothermal

To find : Δs

Diagram :

Analysis : $S_2 - S_1 =$ for an isothermal process
 = $-\frac{Q_{\text{rejected}}}{T}$
 = - 16.65 J/K.

Comment : Entropy decreases as heat is removed from the system.

Prob : 5.2 A mass of 5 kg of liquid water is cooled from 100°C to 20°C. Determine the change in entropy.

System : Closed system

Known : Mass of water = 5kg
 $T_1 = 100^\circ\text{C} = 373 \text{ K}$
 $T_2 = 20^\circ\text{C} = 293 \text{ K}$

Process : Constant pressure

To find : Change in entropy

Diagrams :

Assumptions : 1) The process is reversible

2) The specific heat of liquid water is constant

Analysis : $S_2 - S_1 = m$

For this problem

$$p_2 = p_1 \text{ \& } C_p = 4.186$$

$$\therefore S_2 - S_1 = 5$$

$$= -5.053$$

Comment : Entropy decreases as heat is removed from the system.

Prob : 5.3 Air is compressed isothermally from 100 kPa to 800 kPa. Determine the change in specific entropy of the air.

System : Closed/Open

Known : $p_1 = 100 \text{ kPa}$

$p_2 = 800 \text{ kPa}$

To find : ΔS - change in Specific entropy

Diagram :

Analysis : $\Delta S =$

$$= -R \ln \quad [\text{Since the process is isothermal}]$$

$$= -0.287 \times \ln$$

$$= -0.597 \text{ kJ/kgK.}$$

Prob : 5.4 A mass of 5 kg of air is compressed from 90 kPa, 32°C to 600 kPa in a polytropic process, $pV^{1.3} = \text{constant}$. Determine the change entropy.

System : Closed / Open

Known : $p_1 = 90 \text{ kPa}$

$T_1 = 32^\circ\text{C} = 305 \text{ K}$

$p_2 = 600 \text{ kPa}$

$m = 5 \text{ kg}$

Process : $pV^{1.3} = \text{Constant}$

To find : ΔS - Change in entropy

Diagram :

Analysis : $S_2 - S_1 = m$

Where $T_2 = T_1$

$= 305$

$= 473 \text{ K}$

$\therefore S_2 - S_1 = 5$

$= -0.517 \text{ kJ/K}$.

Comment : For air the ratio of C_p and C_v is equal to 1.4. Therefore the polytropic index $n = 1.3 (< 1.4)$ indicates that some heat is removed from the system resulting in negative entropy.

Prob : 5.5 A rigid insulated container holds 5 kg of an ideal gas. The gas is stirred so that its state changes from 5 kPa and 300 K to 15 kPa. Assuming $C_p = 1.0 \text{ kJ/kgK}$ and $\gamma = 1.4$, determine the change of entropy of the system.

System : Closed

Process : Constant volume since the gas is stirred in an rigid container

Known : $p_1 = 5 \text{ kPa}$

$p_2 = 15 \text{ kPa}$

$m = 5 \text{ kg}$

$C_p = 1.0 \text{ kJ/kgK}$

$T_1 = 300 \text{ K}$

$\gamma = 1.4$

Diagrams :

To find : Change in entropy

Analysis : $S_2 - S_1 = m$

By applying the state equation.

$$\text{Since } V_2 = V_1$$

$$\begin{aligned} \text{Also } R &= C_p - C_v \\ &= \\ &= \\ &= \\ &= 0.286 \text{ kJ/kgK} \end{aligned}$$

Substituting these values we get

$$\begin{aligned} S_2 - S_1 &= 5 \\ &= 3.922 \text{ kJ/K} \end{aligned}$$

Comment : Though this process is adiabatic it is not isentropic since the process of stirring is an irreversible process.

Prob : 5.6 An insulated rigid vessel is divided into two chambers of equal volumes. One chamber contains air at 500 K and 2 MPa. The other chamber is evacuated. If the two chambers are connected, what would be the entropy change ?

System : Closed system

Process : Unresisted expansion

Known : $T_1 = 500 \text{ K}$

$$p_1 = 2 \times 10^3 \text{ kPa}$$

To find : Entropy change

Diagrams :

$$\begin{aligned} \text{Analysis : } s_2 - s_1 &= \\ s_2 - s_1 &= \end{aligned}$$

After expansion air will occupy the entire volume of the container.

$$\therefore V_2 = 2V_1$$

Also ${}_1W_2 = 0$ since it is an unresisted expansion
 $Q_{12} = 0$ since the vessel is insulated

Applying the first law of thermodynamics

$$Q_{12} = \Delta U + {}_1W_2$$

Therefore $\Delta u = 0$

For air

$$mc_v(T_2 - T_1) = 0$$

i.e. $T_2 = T_1$

$$\begin{aligned} \text{Hence } s_2 - s_1 &= C_v \ln + R \ln \\ &= 0.287 \ln \\ &= 0.199 \text{ kJ/kgK} \end{aligned}$$

Comment : Though the process is adiabatic entropy increases as the process involving unresisted expansion is an irreversible process. It also proves the fact that

Prob : 5.7 An adiabatic chamber is partitioned into two equal compartments. On one side there is oxygen at 860 kPa and 14°C. On the other side also, there is oxygen, but at 100 kPa and 14°C. The chamber is insulated and has a volume of 7500 cc. The partition is abruptly removed. Determine the final pressure and the change in entropy of the universe.

System : Closed

Process : Adiabatic Mixing

Known :

	Subsystem I	Subsystem II
Fluid	Oxygen	Oxygen
Initial pressure	850 kPa	100 kPa
Initial Temperature	14°C	14°C
Initial volume		

Diagrams :

Analysis : Here the energy interaction is taking place only between the two fluids and therefore the energy lost by one fluid should be equal to the energy gained by the other fluid. Taking t_f as the final temperature we get

Since the same fluid is stored in both the systems at the same temperature

$$C_1 = C_2 \text{ and}$$

$$t_1 = t_2 = 14^\circ\text{C}$$

Therefore the final temperature will also be 14°C

After removing partition total mass of oxygen is occupying the entire 7500cc at 14°C . Hence the final pressure can be computed as given below :

$$= 0.0427 \text{ kg}$$

$$= 0.00503 \text{ kg}$$

To find the final pressure

$$= m_1 + m_2$$

$$= 475 \text{ kPa}$$

$$\Delta S_{\text{system}} = \Delta S_1 + \Delta S_2$$

$$\Delta S_{\text{surroundings}} = 0$$

$$\Delta S_{\text{universe}} = 8.596$$

Prob : 5.8 Two vessels, A and B each of volume 3 m^3 may be connected by a tube of negligible volume. Vessel A contains air at 0.7 MPa , 95°C while vessel B contains air at 0.35 MPa , 205°C . Find the change of entropy when A is connected to B by working from the first principles and assuming the mixing to be complete and adiabatic.

System : Closed

Process : Adiabatic mixing

<i>Known</i> :	Properties	Subsystem A	Subsystem B
	Fluid	Air	Air
	pressure	0.7 MPa	0.35 MPa
	volume	3 m^3	3 m^3
	Temperature	95°C	205°C

Diagrams :

Analysis : Since the energy interaction is taking place only between the two fluids energy lost by one fluid is equal to the energy gained by the other fluid.

$$\therefore Q_A = Q_B$$

Taking t_2 as the final temperature after mixing $m_a C_a (t_2 - t_{1a}) = m_b C_b (t_{1b} - t_2)$ Since in both A and B the same fluid is stored, $C_a = C_b$

Also $m_a =$

$$=$$

$$= 19.9 \text{ kg}$$

$$m_b =$$

$$=$$

$$= 7.65 \text{ kg}$$

$$19.9 (t_2 - 95) = 7.65 (205 - t_2)$$

$$2.6 (t_2 - 95) = (205 - t_2)$$

$$2.6t_2 + t_2 = 205 + 2.6 \times 95$$

$$t_2 = 125.6^\circ\text{C}$$

$$\text{Entropy change} = \Delta S_A + \Delta S_B$$

$$\Delta S_A = m_A$$

$$\Delta S_B = m_B$$

$$\Delta S_{\text{sys}} = 5.08 + 0.525$$

$$= 5.605$$

$$\Delta S_{\text{surr}} = 0$$

$$\therefore \Delta S_{\text{universe}} = 5.605$$

$$\text{Final pressure } p_2 =$$

$$=$$

$$= 525 \text{ kPa}$$

Prob : 5.9 Air enters a turbine at 400°C, 30 bar and velocity 160 m/s. It leaves the turbine at 2 bar, 120°C and velocity 100 m/s. At steady state it develops 200 kJ of work per kg of air. Heat transfer occurs between the surroundings and the turbine at an average temperature of 350 K. Determine the rate of entropy generation.

System : Open

Process : Steady flow

<i>Known</i> :	Properties	Inlet	Outlet
	Pressure	30 bar	2 bar
	Velocity	160 m/s	100 m/s
	Temperature	400°C	120°C
	Ambient temperature	= 350 K	
	Work output	= 200 kJ/kg	

Diagram :

To find : Rate of entropy generation

Analysis :

$$\text{For unit mass} = C_p \ln$$

$$= 1.005 \ln$$

$$= 0.236 \text{ kJ/kgK}$$

where $Q_{\text{surr}} =$

=

$$Q_{\text{sur}} = +89.2 \text{ kJ/kg}$$

$$(\Delta S)_{\text{sur}} =$$

$$= 0.255 \text{ kJ/kgK}$$

$$= 0.019 \text{ kJ/kgK.}$$

Prob : 5.10 A turbine operating at steady state receives air at a pressure of $p_1 = 3.0$ bar and temperature of 390 K. Air exits the turbine at a pressure of $p_2 = 1.0$ bar. The work developed is measured as 74 kJ/kg of air flowing through the turbine. The turbine operates adiabatically, and changes in kinetic and potential energy between inlet and exit can be neglected. Using ideal gas model for air, determine the turbine efficiency.

System : Open

Process : Steady flow

Known : $p_1 = 3.0$ bar $p_2 = 1.0$ bar
 $T_1 = 390$ K $W_a = 74$ kJ/kg

Diagrams :

Analysis : $\eta_t =$
 $=$ for an ideal gas

Where

$$\therefore T_{2s} =$$

$$\therefore T_{2s} = 284.9 \text{ K}$$

$$= C_p (T_1 - T_2) = 74$$

$$\therefore T_1 - T_2 =$$

$$= 73.63 \text{ K}$$

Hence $\eta_t =$

$=$

$$= 0.7 \text{ (or 70%).}$$

Prob : 5.11 A closed system is taken through a cycle consisting of four reversible processes. Details of the processes are listed below. Determine the power developed if the system is executing 100 cycles per minutes.

Process	Q (kJ)	Temperature (K)
---------	--------	-----------------

		Initial	Final
1 - 2	0	300	1000
2 - 3	+1000	1000	1000
3 - 4	0	1000	300
4 - 1	-	300	300

System : Closed

Process : The system is executing cyclic process.

Known : Heat transfer in process 12, 23 and 34 and temperature change in all the process.
No of cycles per minute.

To find : Power developed.

Diagrams :

Analysis : To find the power developed W_{net} per cycle must be known. From I Law $W_{net} = Q_{net}$ which can be computed from the following table

Process	Q (kJ)	Temperature (K)		ΔS
		Initial	Final	
1 - 2	0	300	1000	0
2 - 3	1000	1000	1000	
3 - 4	0	1000	300	0
4 - 1	-	300	300	ΔS_{41}

For a cyclic process $\Sigma \Delta \phi = 0$

where ϕ is any property

$$\therefore \Sigma \Delta S = 0$$

$$(i.e.,) \quad \Delta S_{12} + \Delta S_{23} + \Delta S_{34} + \Delta S_{41} = 0$$

$$0 + 1 + 0 + \Delta S_{41} = 0$$

$$\Delta S_{41} = -1$$

Since the process 4-1 is isothermal

$$= -1$$

$$Q_{41} = -300 \text{ kJ}$$

Therefore

$$Q_{\text{net}} = Q_{12} + Q_{23} + Q_{34} + Q_{41}$$

$$= 0 + 1000 + 0 - 300$$

$$= 700 \text{ kJ per cycle}$$

$$\therefore W_{\text{net}} = Q_{\text{net}} = 700 \text{ kJ}$$

and power developed

$$=$$

$$= 700$$

$$= 1166.7 \text{ kW}$$

Prob : 5.12 Two kilogram of air is heated from 200°C to 500°C at constant pressure. Determine the change in entropy.

System : Open/closed

Working fluid : Air

Process : Constant pressure heating

Known : 1) $t_1 = 200^\circ\text{C}$
2) $t_2 = 500^\circ\text{C}$

Diagram :

To find : Change in entropy ΔS

Analysis : $\Delta S =$

$$=$$

$$=$$

$$= 0.987 \text{ kJ/K}$$

Prob : 5.13 A Carnot engine operated between 4°C and 280°C. If the engine produces 300 kJ of work, determine the entropy change during heat addition and heat rejection.

System : Open/closed

Process : The working fluid is executing Carnot cycle

Known : 1) $t_1 = 280^\circ\text{C}$
2) $t_2 = 4^\circ\text{C}$
3) $W = 300 \text{ kJ}$

Diagram :

To find : 1) ΔS during heat addition
2) ΔS during heat rejection

Analysis : 1) In carnot engine heat is added at constant temperature

Therefore $\Delta S =$

Where $Q_{in} =$

$\eta =$

$=$

$= 0.499$

Therefore $Q_{in} =$

$= 601.1 \text{ kJ}$

$\Delta S =$

$=$

$= 1.087 \text{ kJ/K}$

2) In carnot engine heat rejection is also taking place at constant temperature

Therefore $\Delta S =$

Where $Q_{out} = Q_{in} - W$

$= 601.1 - 300$

$= 301.1 \text{ kJ}$

$\Delta S =$

$= -1.087 \text{ kJ/K}$

Comment : In a carnot cycle two isothermal processes and two isentropic processes. Therefore ΔS during heat addition must be equal to ΔS during heat rejection so that

which obeys Clausius Inequality.

Prob : 5.14 Air flows through a perfectly insulated duct. At one section A the pressure and temperature are respectively 2 bar 200°C and at another section B further along the duct the corresponding values are 1.5 bar and 150°C. Which way the air is flowing?

System : Open

Process : Steady flow process

Known : 1) $p_1 = 2 \text{ bar}$

2) $t_1 = 200^\circ\text{C}$

3) $p_2 = 1.5 \text{ bar}$

4) $t_2 = 150^\circ\text{C}$

To find : To know flow direction

Diagram :

Analysis : This problem cannot be solved by simple application of first law of thermodynamics. Because there is nothing to tell us whether the fluid is expanding from A to B or being compressed from B to A.

However, since the duct is insulated the inference is that there is no heat transfer to or from the environment and therefore there is no change of entropy in the environment. But in any real process change of entropy of the system plus the surroundings must be positive. In other words $\Delta S_{AB} > 0$

Thus $S_A > S_B$ and the flow is from B to A.

Even though entropy cannot be measured directly it can still be used to find the sense of flow in a well insulated duct given two salient states as above.

Prob 5.15: A certain fluid undergoes expansion in a nozzle reversibly and adiabatically from 500 kPa, 500 K to 100 kPa. What is the exit velocity? Take $\gamma = 1.4$ and $R = 0.287$.

System : Open

Process : Reversible adiabatic expansion

Known :

- 1) Inlet pressure = 500 kPa
- 2) Inlet temperature = 500 K
- 3) Exit pressure = 100 kPa
- 4) The ratio of Specific heats = 1.4
- 5) Characteristic Gas constant = 0.287

To find : Exit velocity

Diagram :

Analysis : Applying Steady Flow Energy Equation

Therefore

where C_p and T_2 are unknowns.

To find C_p

$$C_p - C_v = R$$

Substituting γ and R we get

To find T_2

It is stated in the problem that the process of expansion is reversible.
Therefore

Also the process is given as adiabatic. That is

$$(or) \quad ds = 0$$

$$S_2 - S_1 = 0$$

$$= 315.8 \text{ K}$$

Substituting numerical values for T_2 and C_p , we get

Prob 5.16: Show from the first principle that, for a perfect gas with constant specific heat capacities expanding polytropically ($pV^n = \text{constant}$) in a non-flow process, the change of entropy can be expressed by

Gaseous methane is compressed polytropically by a piston from 25°C and 0.8 bar to a pressure of 5.0 bar. Assuming an index of compression of 1.2, calculate the change of entropy and workdone, per unit mass of gas. The relative molecular weight of methane is 16 and $\gamma = 1.3$.

System : Closed

Process : Polytropic ($pV^n = C$)

Known : 1) $T_1 = 298 \text{ K}$

2) $p_1 = 80 \text{ kPa}$

3) $p_2 = 500 \text{ kPa}$

4) $n = 1.2$

$$5) M = 16$$

$$6) \gamma = 1.3$$

To find :

1) ${}_1W_2$ – Work done

2) ΔS – Change in entropy

Analysis : a) To prove $S_2 - S_1 =$

From First Law of Thermodynamics

$$Q_{12} = {}_1W_2 + \Delta U$$

In differential form

for a polytropic process

Therefore

Upon integration we get

From the process relation

Substituting for we get

We know that $R = C_p - C_v$

$$R = C_v (\gamma - 1)$$

Substituting for C_v we get

(2) Workdone

$$= 404.45 \text{ K}$$

Substituting numerical values

(3) Change in entropy

Comment : The negative sign in work indicates that work is given into the system. The negative sign in entropy change indicates that there is a heat rejection by the system to the ambient during compression.

Prob 5.17: A closed system undergoes the internally reversible process as shown below :

Compute the heat transfer.

System : Closed

Process : Defined by a straight line on a T-S diagram.

Known : $T_1 = 200 \text{ K}$

$T_2 = 600 \text{ K}$

$S_1 = 1 \text{ kJ/K}$

$S_2 = 3 \text{ kJ/K}$

To find : Heat transfer

Analysis : $Q = \text{Area under the curve representing the process in a T-S diagram}$
 $= 800 \text{ kJ}$

Prob 5.18: In a refrigerant condenser superheated vapour of ammonia enters steadily at 1.4 MPa, 70°C. It leaves the condenser at 20°C. At 1.4 MPa condensation begins and ends at 36.28°C. Cooling water enters the condenser at 10°C and leaves 15°C. Determine

- (a) the amount of heat rejected per kg of ammonia vapour condensed for the given inlet and exit conditions.
- (b) mass of water to be supplied for each kg of ammonia vapour condensed
- (c) the change in specific entropy of ammonia
- (d) the entropy generation per kg of ammonia

Take $C_{p_{\text{vapour}}} = 2.9 \text{ kJ/kgK}$, $C_{p_{\text{liquid}}} = 4.4 \text{ kJ/kgK}$ and latent heat of evaporation of ammonia at 1.4 MPa is 1118 kJ/kg. Also represent the process in a T-s diagram.

System : Open

Process : Steady flow process

Known : $T_1 = 70^\circ\text{C}$
 $P_1 = 1.4 \text{ MPa}$
 $T_2 = 20^\circ\text{C}$
 $T_{w_1} = 10^\circ\text{C}$
 $T_{w_2} = 15^\circ\text{C}$

To find : (a) the amount of heat rejected per kg of ammonia vapour condensed for the given inlet and exit conditions.
(b) mass of water to be supplied for each kg of ammonia vapour condensed
(c) the change in specific entropy of ammonia
(d) the entropy generation per kg of ammonia

Diagrams :

Analysis : (a) Heat rejected per kg of ammonia

$$\begin{aligned} Q_{1-2} &= Q_{1-2a} + Q_{2a-2b} + Q_{2b-2} \\ &= 2.9 (70 - 36.28) + 1118 + 4.4 (36.28 - 20) \\ &= 1287.42 \text{ kJ/kg} \end{aligned}$$

(b) Water flow rate required per kg of ammonia

$$= 61.51$$

(c) Change in Specific entropy of ammonia

$$\begin{aligned} &= \Delta S_{1-2a} + \Delta S_{2a-2b} + \Delta S_{2b-2} \\ &= -4.153 \end{aligned}$$

(d) $\Delta S_{\text{universe}} = \Delta S_{\text{Water}} + \Delta S_{\text{ammonia}}$

$$\begin{aligned} \text{where } \Delta S_{\text{Water}} &= mC_p \ln \\ &= 61.51 \times 4.186 \times \ln \\ &= 4.509 \end{aligned}$$

Substituting the values we get

$$\begin{aligned} \Delta S_{\text{universe}} &= 4.509 + (-4.153) \\ &= 0.356 \end{aligned}$$

Comment : As heat is removed from ammonia its entropy decreases whereas entropy of water increases as it receives heat. But total entropy change will be positive as heat is transferred through finite temperature difference.

Prob 5.19: The specific heats of a gas are given by $C_p = a + kT$ and $C_v = b + kT$, where a , b and k are constants and T is in K. Show that for an isentropic expansion of this gas

$$T^b v^{a-b} e^{kT} = \text{constant}$$

System : Closed

Process : Isentropic

Known : 1) $C_p = a + kT$

2) $C_v = b + kT$

To prove : $T^b v^{a-b} e^{kT} = \text{constant}$ for an isentropic process

Proof : For a gas

$$C_p - C_v = (a + kT) - (b + kT)$$

$$\text{(or) } R = a - b$$

For an isentropic process

$$ds = 0$$

(or)

Substituting for C_v and R

Upon integration

$$b \ln T + kT + (a - b) \ln v = \text{constant}$$

Taking antilog

$$T^b e^{kT} v^{a-b} = \text{constant}$$

Prob 5.20: Calculate the entropy change of the universe as a result of the following process :

- (a) A metal block of 0.8 kg mass and specific heat capacity 250 J/kgK is placed in a lake at 8°C
- (b) The same block, at 8°C, is dropped from a height of 100 m into the lake.
- (c) Two such blocks, at 100°C and 0°C, are joined together.

Case (a)

System : A metal block

Process : Cooling the metal block by dipping it in a lake.

Known : 1) Initial temperature of the block (T_1) = 100 + 273 = 373 K
 2) Final temperature of the block (T_2) = 8 + 273 = 281 K
 3) Mass of the metal block (m) = 0.8 Kg
 4) Specific heat capacity of the metal block (C) = 250

To find : Entropy change of the universe

Diagram :

Analysis :
$$\Delta S_{\text{universe}} = \Delta S_{\text{system}} + \Delta S_{\text{surroundings}}$$

Where

Where
$$\begin{aligned} Q_{\text{sur}} &= -Q_{\text{sys}} \\ &= -mC(T_2 - T_1) \\ &= -0.8 \times 250 (281 - 373) \\ &= 18400 \text{ J} \end{aligned}$$

Substituting the values we get

$$\begin{aligned} \Delta S_{\text{universe}} &= -56.6 + 65.48 \\ &= 8.84 \text{ J/K} \end{aligned}$$

Comment : As discussed earlier the entropy change of the universe is positive. The reason is the irreversible heat transfer through finite temperature difference from the metal block to the lake.

Case (b)

- System* : A metal block
- Process* : Falling of the metal block into the lake and reaching equilibrium
- Known* : 1) Initial Temperature = 281 K
2) Final Temperature = 281 K
3) Initial height = 100 m
4) mass of the metal block (m) = 0.8 kg
5) Specific heat capacity of the metal block (C) = 250 J/kgK
- Diagrams* :

Analysis : $\Delta S_{\text{universe}} = \Delta S_{\text{system}} + \Delta S_{\text{surroundings}}$

Where $\Delta S_{\text{system}} = 0$, as the system is at the same temperature at both the initial and final state.

$$\begin{aligned} Q_{\text{surroundings}} &= \Delta E_{\text{system}} \\ &= mgh \\ &= 0.8 \times 9.81 \times 100 = 784.8 \text{ J} \end{aligned}$$

Comment : Increase in entropy of the universe indicates that there is a irreversibility or degradation of energy. That is the high grade potential energy is converted low grade energy during this process.

Case (c)

- Systems* : Two metal blocks
- Process* : Two metal blocks are brought in thermal contact and allowed to reach equilibrium.
- Known* : Initial temperatures of the blocks
 $T_{1a} = 373 \text{ K}$

$$T_{1b} = 273 \text{ K}$$

To find : Entropy change of the universe

Diagrams :

Analysis : $\Delta S_{\text{universe}} = \Delta S_a + \Delta S_b$

Where

To find T_2

$$Q_a = -Q_b$$

$$mc(T_2 - T_{1a}) = -mc(T_2 - T_{1b})$$

Comment : In this process also the heat transfer through finite temperature difference makes the process irreversible which in turn results in increase in entropy of the universe.

Prob 5.21: Each of three identical bodies satisfies the equation $U = CT$, where C is the heat capacity of each of the bodies. Their initial temperatures are 200 K, 250 K and 540 K. If $C = 8.4 \text{ kJ/K}$, what is the maximum amount of work that can be extracted in a process in which these bodies are brought to a final common temperature ?

System : Three identical bodies

Process : Extracting work with heat transfer among the three bodies so that they reach a common temperature.

Known : Initial temperature of the three bodies

$$T_{1a} = 540 \text{ K}$$

$$T_{1b} = 250 \text{ K}$$

$$T_{1c} = 200 \text{ K}$$

Heat capacity of all the three bodies = 8.4 T

To find : The maximum amount of work that can be extracted.

Diagram :

Analysis : Let us assume that the final temperature is greater than 250 K, so that heat is transferred from body (1) to bodies (2) and (3).

The net work obtained

$$\begin{aligned}W &= Q_1 - Q_2 - Q_3 \\&= (\Delta U)_1 - (\Delta U)_2 - (\Delta U)_3 \\&= C [(540 - T_2) - (T_2 - 250) - (T_2 - 200)] \\&= 8.4 [990 - 3T_2]\end{aligned}$$

This work will be maximum if the process under consideration is reversible. Therefore

$$\Delta S_1 + \Delta S_2 + \Delta S_3 = 0$$

Therefore $T_2 = 300$ K

This is the condition for the process to be reversible. Hence the maximum work that can be obtained is

$$\begin{aligned}W_{\max} &= 8.4 (990 - 3 \times 300) \\&= 8.4 (90) \\&= 756 \text{ kJ}\end{aligned}$$

Prob 5.22: A resistor of 50 ohm resistance carries a constant current of 5A. The ambient temperature and the temperature of the resistor remain to be 27°C over a period of 10 seconds. What is the entropy change of the resistor, ambient and the universe ?

System : A resistor

Process : Passing of the electrical current through a resistor at constant temperature.

Known : 1) Initial and final temperature of the resistor = 300 K
2) Ambient Temperature = 300 K
3) Duration (τ) = 10 seconds

To find :

$$1) \Delta S_{\text{resistor}}$$

$$2) \Delta S_{\text{ambient}}$$

$$3) \Delta S_{\text{universe}}$$

Analysis :

$$\begin{aligned}\Delta S_{\text{universe}} &= \Delta S_{\text{resistor}} + \Delta S_{\text{ambient}} \\ &= 0 + 41.7 \\ &= 41.7\end{aligned}$$

Comment : When current passes through a resistor it is converted into heat. As the resistor is to be maintained at the same temperature the heat is dissipated into the ambient and hence the process is irreversible resulting in increase of entropy of the universe.

Prob 5.23 : A closed system is assumed to have a heat capacity at constant volume where $a = 0.002$ and T is the temperature in K.

The system is originally at 600 K and a thermal reservoir at 300 K is available. What is the maximum amount of work that can be recovered as the system is cooled down to the temperature of the reservoir ?

System : A closed system

Process : Obtaining work with the help of the heat transfer from the system to the reservoir.

Known : 1) $C_v = e^{0.002T}$

$$2) T_1 = 600 \text{ K}$$

$$3) T_2 = 300 \text{ K}$$

To find : W_{max}

Diagram :

Analysis : $Q_1 = \Delta U$

If the work is to be maximum, the process must be reversible. Therefore

$$(\Delta S)_{\text{universe}} = 0$$

$$\Delta S_{\text{system}} + \Delta S_{\text{reservoir}} = 0$$

Neglecting higher order terms,

$$\begin{aligned}\text{Therefore } \Delta S_{\text{reservoir}} &= -\Delta S_{\text{system}} \\ &= 1.731\end{aligned}$$

$$\begin{aligned}\text{Thus maximum work} &= Q_1 - Q_2 \\ &= 911 - 519.3 \\ &= 391.7 \text{ kJ}\end{aligned}$$

Exercises

1. $\Delta S = 0$ for _____ processes

Ans : Reversible

2. Entropy is a point function (True / False)

Ans : True

3. Entropy change of universe can never be negative (True / False)

Ans : True

4. All the isentropic processes are reversible adiabatic processes (True / False)

Ans : False

5. What is the difference between adiabatic and isentropic process?
6. A system is losing 500 kJ of heat at a constant temperature of 500 K. What is the change in entropy ?
7. Area under any curve in T-s diagram represents _____.

Ans : heat

8. $p = \text{constant}$ lines are steeper than $v = \text{constant}$ lines in T-S diagram (True/False)

Ans : False

9. During throttling process entropy _____ (Increases / Decreases) for an ideal gas.

Ans : Increases

10. Find the entropy change of the universe when 1000 kJ of heat is transferred from 800 K to 500 K.

11. Give the expression for change in entropy during isothermal processes and polytropic processes.

12. Calculate the change in entropy per kg of air when it expands isothermally from 6 bar to 3bar.

13. A closed system undergoes an adiabatic process. Work done on the system is 15 kJ/kg. The entropy change of the system

- a) is positive
b) is negative
c) can be positive or negative

Ans : positive

14. Give the interpretation of entropy from microscopic point of view.

15. A quantity of gas has an initial pressure, volume and temperature of 140 kPa, 0.14 m^3 and 25°C respectively. It is compressed to a pressure of 1.4 MPa according to the law $pV^{1.25} = C$. Determine the change in entropy

Take $c_p = 1.041 \text{ kJ/kgK}$, $c_v = 0.743 \text{ kJ/kgK}$.

Ans : - 0.207 kJ/kgK

16. 1 kg of air has a volume of 56 litres and a temperature of 190°C . The air then receives heat at constant pressure until its temperature becomes 500°C . From this state the air rejects heat at constant volume until its pressure is reduced to 700 kPa. Determine the change of entropy during each process, stating whether it is an increase or decrease.

Ans : 0.516 kJ/kgK, an increase - 0.88 kJ/kgK, an decrease

17. A quantity of gas has an initial pressure, volume and temperature of 1.1 bar, 0.16 m^3 and 18°C respectively. It is compressed isothermally to a pressure of 6.9 bar. Determine the change of entropy. Take $R = 0.3 \text{ kJ/kgK}$.

Ans : -0.111 kJ/K

18. A reversible heat engine shown in figure below operates between three constant temperature reservoirs at 600 K, 400 K and 300 K.

It receives 2500 kJ of energy of heat from the reservoir at 600 K and does 1000 kJ of work. Determine the heat interactions with the other two reservoirs.

Ans : $Q_2 = 1008$, $Q_3 = 4926$

19. A block of copper with a mass of 1.5 kg is initially at 700 K. It is allowed to cool by means of heat transfer to the surrounding air at 300 K. Determine the change in entropy of the copper and change in entropy of the universe after copper reaches thermal equilibrium. Assume specific heat of copper is 0.39 kJ/kgK.

Ans : - 0.4967 kJ/K, +0.2843 kJ/K

20. Using the principle of increase in entropy prove that the heat transfer is always from a high-temperature body to a low temperature body.
21. Nitrogen at 420 K and 1.4 MPa is expanded reversibly and adiabatically in a nozzle to exit pressure of 700 kPa. Determine the temperature and velocity of the nitrogen at the exit of the nozzle. Take $\gamma_{N_2} = 1.40$.
22. A vessel is divided into two temperature by means of a membrane as shown in the figure given below. What will be the final state of air and change in entropy of the universe if the membrane is removed.

Ans : $P_f = 750.14$ kPa, $T_f = 65.11^\circ\text{C} = 0.373$

23. A given gaseous system undergoes an isentropic process from state 1 to state 2.
- a) Combine the two relations $p = RT$ and $p v^\gamma = C$ and show that
- b) Integrate the two expressions, using $p v^\gamma = C$ and show that γ is γ times γ by comparison.

24. During the isentropic process of 1.36 kg/s of air, the temperature increases from 4.44°C to 115.6°C. For a non-flow process and for a steady flow process find
- Change in internal energy
 - Work done
 - Change in enthalpy
 - Change in entropy and
 - Heat transfer
25. Air at 5 bar, 100°C, expands reversibly in a piston-cylinder arrangement. It expands to 2 bar in an isothermal process. Calculate
- heat transfer per unit mass of air
 - change in specific internal energy
 - change in specific entropy
26. One kg of air at 1 bar, 20°C, is compressed according to the law $pv^{1.3} = \text{constant}$ until the pressure is 5 bar. Calculate the change in entropy and sketch the process on a T-S diagram indicating the area representing the heat flow.
27. 1 kg of air at 1 bar, 25°C, changes its state to 6 bar and a volume of 1 m³. Calculate the change of entropy and sketch the initial and final state points on the p-v and T-S fields.
28. 0.5 m³ ethane (C₂H₄) at 7 bar, 260°C expand isentropically in a cylinder behind a piston to 1 bar, 100°C. Calculate the workdone in expansion assuming ethane as perfect gas. The same mass is now recompressed back to 7 bar according to the law $pv^{1.35} = \text{constant}$. Calculate the final temperature and the heat transfer. Calculate also the change in entropy and sketch both process on the p-v and T-S fields. Take $C_p =$ for ethane.
29. A mass m of water at T_1 is mixed with equal mass of water at T_2 at the same pressure in an insulated mixing chamber. Show that the entropy change of the Universe is given as
30. Consider a closed system consisting of air as working fluid in a piston cylinder arrangement as shown in the Figure.
- The weight placed on the piston is such that the air occupies a volume of 1.5 litre when there exist thermodynamic equilibrium between the system and its surroundings. The corresponding pressure and temperature are 2 bar, 30°C. Heat is added until the pressure

increases to 5 bar. Volume of air when the piston touches the stop is 3 litres. Find the following

- a) Final temperature
 - b) Workdone
 - c) Heat transformed
 - d) Change in entropy
31. An ideal vapour absorption refrigeration system may be considered as the combination of the reversible heat engine operating a reversible refrigerator as given in the following diagram. Obtain the COP of the refrigeration system which is defined as the ratio of Q_c to Q_g .
32. Vapour absorption heat transformer is a novel device used for upgrading a portion of waste heat from low temperature to high temperature. An ideal vapour absorption heat transformer may be considered as the combination of the reversible heat engine operating a reversible heat pump as given in the following diagram. Obtain the COP of the vapour absorption heat transformer which is defined as the ratio of Q_a to $(Q_g + Q_c)$.

Chapter 6

AVAILABLE ENERGY, AVAILABILITY AND IRREVERSIBILITY

From second law of thermodynamics we found that complete conversion of heat into work is not possible in a continuous process. Also it has been proved that the most efficient cycle to produce work is a reversible power cycle (Carnot cycle). Even in Carnot cycle, the efficiency of conversion can never be unity and hence to establish a comparison of the work-energy conversion in actual processes, the maximum theoretical work obtainable with respect to some datum must be determined. This chapter is dedicated for this objective.

6.1 Available and Unavailable Energy

The energy content of a system can be divided into two parts

- Available energy, which under ideal conditions may be completely converted into work
- Unavailable energy which is usually rejected as waste.

Consider Q units of heat energy available at a temperature T . Available part of energy can be obtained by assuming that the heat is supplied to a Carnot engine. Work obtained from the Carnot engine $\left(\frac{T - T_0}{T}\right)Q$ is the available part. The quantity $\left(\frac{T_0}{T}\right)Q$ is the unavailable part. In a T-S diagram these quantities can be represented as shown in the fig 6.1. The term T_0 is the ambient temperature. Hence it can be concluded that the available and unavailable part of energy content of a system depends on the ambient conditions also.

6.2 Reversible Work In A Non-flow Process

From first law of thermodynamics

$$Q_{sys} - W = U_2 - U_1 \quad \dots 6.1$$

From second law of thermodynamics for a reversible process

$$\begin{aligned} (\Delta s)_{universe} &= (\Delta s)_{system} + (\Delta s)_{surroundings} \\ &= 0 \end{aligned} \quad \dots 6.2$$

$$\text{Where } (\Delta s)_{system} = S_2 - S_1$$

$$(\Delta s)_{surroundings} = \frac{Q_{surr}}{T_{Surr}} = \frac{-Q_{Sys}}{T_0}$$

where,

$$Q_{system} = T_0(S_2 - S_1) \quad \dots 6.3$$

substituting in 6.1 we get

$$T_o(S_2 - S_1) - W = U_2 - U_1$$

$$\therefore W = (U_2 - U_1) - T_o(S_1 - S_2)$$

since the process is reversible W can be represented W_{rev}

$$\therefore W_{rev} = (U_1 - U_2) - T_o(S_1 - S_2) \quad \dots 6.4$$

This is also the maximum work in the process.

For a closed system, when undergoing change in volume, the work done against the atmospheric pressure:

$$W_{atm} = p_o(V_2 - V_1)$$

But this work is not an useful work and hence

$$W_{max,useful} = W_{max} - W_{atm}$$

$$= [(U_1 - U_2) - T_o(S_1 - S_2)] - p_o(V_2 - V_1)$$

$$= (U_1 - U_2) + p_o(V_1 - V_2) - T_o(S_1 - S_2) \quad \dots 6.5$$

6.3 Reversible Work In A Steady-state Control Volume

Steady flow energy equation for a constant volume is

$$\dot{Q} - \dot{W}_{rev} = \sum_{out} \dot{m}_{out} \left(h + \frac{C^2}{2} + gZ \right) - \sum_{in} \dot{m}_{in} \left(h + \frac{C^2}{2} + gZ \right)$$

for a single inlet and outlet

$$\dot{Q} - \dot{W}_{rev} = \dot{m} \left[(h_2 - h_1) + \left(\frac{C_2^2 - C_1^2}{2} \right) + g(Z_2 - Z_1) \right]$$

...6.6

From Second law of thermodynamics

$$\Delta s_{universe} = (\Delta s)_{cv} + (\Delta s)_{surr}$$

$$= 0$$

where

$$\Delta s_{CV} = \dot{m}[(s_2 - s_1)]$$

$$\Delta s_{Sur} = \frac{-\dot{Q}}{T_o}$$

Substituting these values we get

$$\dot{m}(s_2 - s_1) = \frac{\dot{Q}}{T_o}$$

$$\dot{Q} = T_o \dot{m}(s_2 - s_1)$$

From eqn 6.6 neglecting kinetic and potential energy changes

$$\dot{W}_{rev} = \dot{m}[(h_1 - h_2) - T_o(s_1 - s_2)] \quad \dots 6.7$$

In an open system a fixed volume in space known as control volume is taken for analysis. Hence the atmospheric work term $p_o(V_1 - V_2)$ should not be considered. Therefore

$\dot{W}_{rev} = \dot{W}_{max,useful}$ for an open system

6.4 Availability

The maximum useful work that can be obtained from the system such that the system comes to a dead state, while exchanging heat only with the surroundings, is known as availability of the system. Here the term dead state means a state where the system is in thermal and mechanical equilibrium with the surroundings.

Therefore for a closed system availability can be expressed as

$$\phi = (U - U_o) + p_o(V - V_o) - T_o(S - S_o)$$

similarly for an open system

$$\psi = (H - H_o) - T_o(S - S_o)$$

In steady flow systems the exit conditions are assumed to be in equilibrium with the surroundings. The change in availability of a system when it moves from one state to another can be given as:

for a closed system

$$\phi_1 - \phi_2 = (U_1 - U_2) + p_o(V_1 - V_2) - T_o(S_1 - S_2) \quad \dots 6.10$$

for an open system

$$\psi_1 - \psi_2 = (H_1 - H_2) - T_o(S_1 - S_2). \quad \dots 6.11$$

6.5 Availability Change Involving Heat Exchange with Reservoirs

Consider a system undergoing a change of state while interacting with a reservoir kept at T_R and atmosphere at pressure p_o and temperature T_o . Net heat transfer to the system

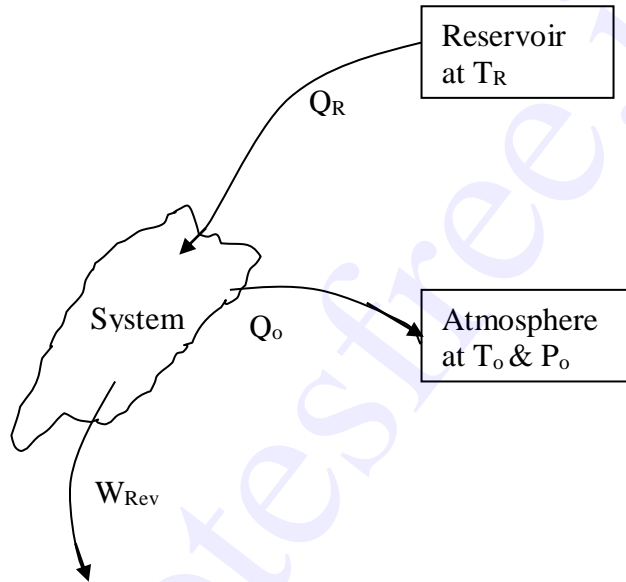

$$Q_{\text{net}} = Q_R - Q_o.$$

From first law of thermodynamics

$$Q_{\text{net}} - W_{\text{rev}} = U_2 - U_1 \quad \dots 6.12$$

From second law of thermodynamics, assuming the process to be reversible

$$(\Delta s)_{\text{Res}} + (\Delta s)_{\text{atm}} + (\Delta s)_{\text{sys}} = 0$$

$$\frac{-Q_R}{T_R} + \frac{Q_o}{T_o} + (S_2 - S_1) = 0$$

The negative sign for Q_R shows that the heat is removed from the reservoir.

By rearranging We get

$$Q_o = Q_R \frac{T_o}{T_R} + T_o(S_1 - S_2)$$

Net heat transferred

$$Q_{net} = Q_R - Q_o$$

$$Q_{net} = Q_R - Q_R \frac{T_o}{T_R} - T_o(S_1 - S_2) \quad \dots 6.13$$

Substituting 6.13 in 6.12 we get

$$Q_R - Q_R \frac{T_o}{T_R} - T_o(S_1 - S_2) - W_{rev} = U_2 - U_1$$

$$W_{rev} = U_1 - U_2 - T_o(S_1 - S_2) + Q_R \left(1 - \frac{T_o}{T_R} \right) \quad \dots 6.14$$

$$W_{max, useful} = U_1 - U_2 + p_o(V_1 - V_2) - T_o(S_1 - S_2) + Q_R \left(1 - \frac{T_o}{T_R} \right) \quad \dots 6.15$$

6.6 Irreversibility

Work obtained in an irreversible process will always be less than that of a reversible process. This difference is termed as irreversibility (i.e) the difference between the reversible work and the actual work for a given change of state of a system is called irreversibility.

$$I = W_{rev} - W_{act}$$

Let a stationary closed system receiving Q kJ of heat is giving out W_{act} kJ of work. From first law of thermodynamics.

$$Q - W_{act} = U_2 - U_1$$

$$W_{act} = U_1 - U_2 + Q$$

$$W_{rev} = (U_1 - U_2) - T_o(S_1 - S_2)$$

$$= (U_1 - U_2) + T_o(\Delta s)_{system}$$

$$\therefore I = W_{rev} - W_{act}$$

$$= (U_1 - U_2) + T_o(\Delta s)_{system} - (U_1 - U_2) - Q$$

$$= T_o(\Delta s)_{system} - Q \quad \text{Where } Q = -Q_{surroundings} = T_o(\Delta s)_{surroundings}$$

$$= T_o(\Delta s)_{system} + T_o \Delta s_{surroundings}$$

$$= T_o(\Delta s)_{universe}$$

Since $(\Delta s)_{\text{universe}}$ will be positive for an irreversible flow, irreversibility will be zero for a reversible process and will never be negative.

$$I \geq 0$$

Similarly for a steady flow system

$$I = W_{\text{rev}} - W_{\text{act}}$$

Where

$$\dot{W}_{\text{rev}} = \dot{m}[(h_1 - h_2) - T_o(s_1 - s_2)]$$

$$W_{\text{act}} = \dot{m}[(h_1 - h_2)] + Q_{\text{sys}}$$

$$Q_{\text{sys}} = Q_o = T_o \Delta s_{\text{surroundings}}$$

Therefore

$$I = T_o(S_1 - S_2) + T_o \Delta s_{\text{surroundings}}$$

$$= T_o[\Delta s_{\text{sys}} + \Delta s_{\text{surroundings}}]$$

$$= T_o[\Delta s_{\text{universe}}]$$

Chapter 7

Properties of Pure Substances

If any two independent intensive properties of a simple compressible system are defined, other properties automatically assume definite values. These properties can be expressed in terms of charts, tables or equations. This chapter covers the charts and tables of properties of steam.

7.1 Pure Substances

Substances of fixed chemical composition are known as pure substances

Example : Water, Helium, Nitrogen, Oxygen etc.

Substances exist in any one of the three phases namely solid, liquid and gas. For example, H_2O may exist in the form ice (solid), Water (Liquid) or Steam (Gaseous). In all these phases it will have the same chemical composition.

A Mixture of two or more phases of a pure substance should also be regarded as pure substance. If Water and Steam Co-exists in a container, the chemical composition of both the Vapour and liquid phases will be identical. Hence this heterogeneous system is also a pure substance.

7.2 Phase Transformation

Consider a unit mass of ice heated steadily at a constant pressure of 1 atm. Let the initial temperature be -30°C . Due to heating, temperature increases upto 0°C (Figure 7.1). At 0°C ice starts melting. Until entire mass of ice becomes water, temperature is remaining constant. Heat added during this phase change is known as latent heat of fusion.

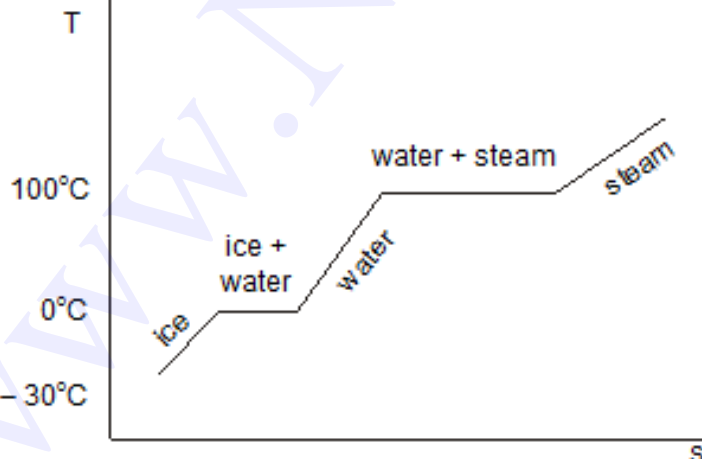

Further heating increases the temperature of water. This continues until 100°C . At 100°C Evaporation of water into steam is taking place. Temperature once again remains constant at

100°C until complete conversion of water into steam occurs. Heat added during this phase change is known as latent heat of evaporation. Temperature of steam continues to increase afterwards.

7.3 p -T Diagram of a Pure Substance

Instead of 1 atm. pressure, if water is heated at 5 bar, evaporation will be taking place at 151.86°C. In the similar manner, each pressure has its own saturation temperature for a given substance.

In a p-T diagram the locus of saturation temperatures against the corresponding pressures forms a curve known as vaporisation curve. It separates liquid and vapour phases in p-T diagram.

Similarly solid & liquid phases are separated by fusion curve in p-T diagram.

Below a limiting value of pressure known as Triple point, direct conversion of solid into vapour is taking place. This is known as sublimation. Sublimation curve separates solid and vapour phases in p-T diagram. Sublimation curve, vaporisation curve and fusion curve are represented on a p-T Coordinates in Figure 7.2. Sublimation and vaporisation curves are having positive slopes for all substances. Fusion curve for most of the substances is having positive slope but for water it is negative. From p-T diagram it can be inferred that the given substance exists in liquid phase when the temperature is below the saturation temperature corresponding to the given pressure and in vapour phase if the given temperature is greater than the saturation temperature. When the given temperature is equal to the saturation temperature it may be liquid, vapor (or) a mixture of both.

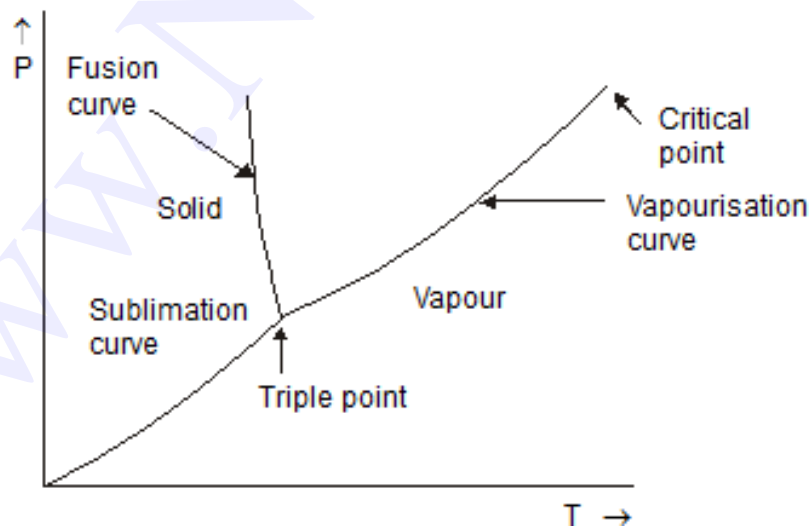

7.4 T-v Diagram of a Pure Substance

For simplicity let us consider only the liquid and vapour phases, which are commonly encountered in most of the engineering applications. Let a system of unit mass of water be heated at constant pressure. 1-2-3-4 in Figure 7.3 Shows the T-v Variations at constant pressure.

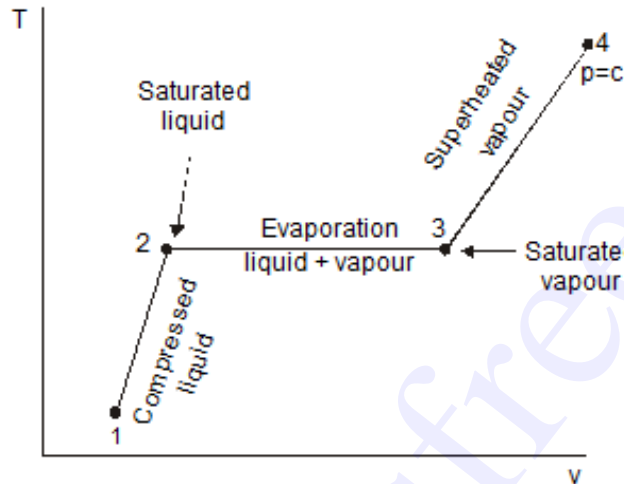

From 1 to 2, heat addition increases the temperature with a very small increase in volume. State of water between 1 to 2 is known as subcooled liquid or compressed liquid because for a given pressure it is at a temperature lower than the saturation temperature (or) for a given temperature it is at a pressure higher than saturation pressure. The state of water at 2 is known saturated liquid. Temperature at this state is equal to the saturation temperature. Any further addition of heat causes evaporation of water.

From 2-3 evaporation is taking place. During this phase change, temperature remains constant and increase in volume is high. At state 3, entire mass is in the form of vapour known dry saturated vapour.

From 3 to 4, heating causes increase in both temperature and volume. State of steam in this region is called super heated state.

As mentioned earlier, at higher pressure evaporation occurs at higher temperature and at lower pressure evaporation occurs at lower temperature. Latent heat of evaporation decreases with increase in pressure. For a particular pressure it becomes zero so that the change from liquid to vapour phase occurs suddenly without a distinct intermediate state. This pressure is known as critical pressure. This state on a property diagram is known as critical point. By connecting the saturated liquid state at different pressures a line called saturated liquid line is obtained. In the same way, by connecting the saturated vapour states, saturated vapour line is obtained. It can be observed that the saturated liquid and vapour line meet at critical point. Figure 7.4. Shows all these lines and various regions on a T-v diagram.

The region between saturated liquid line and saturated vapour line is known as wet region, consisting of both liquid and vapour. The percentage of composition or quality of this wet steam

is expressed in terms of dryness fraction which is defined as the ratio of mass of vapour to the mass of the mixture. Specific volume of *wet steam* is expressed as

$$\begin{aligned} v &= xv_g + (1-x)v_f \\ &= v_f + x(v_g - v_f) \\ &= v_f + xv_{fg} \end{aligned} \quad \dots(7.1)$$

Where v_f - specific volume of the saturate liquid @ the given Pressure or Temperature
 v_g - specific volume of sat. vapour @ the given Pressure or Temperature
 x - dryness fraction.

Since $v_f \ll v_g$

$$v \approx v_f + xv_g \quad \dots(7.2)$$

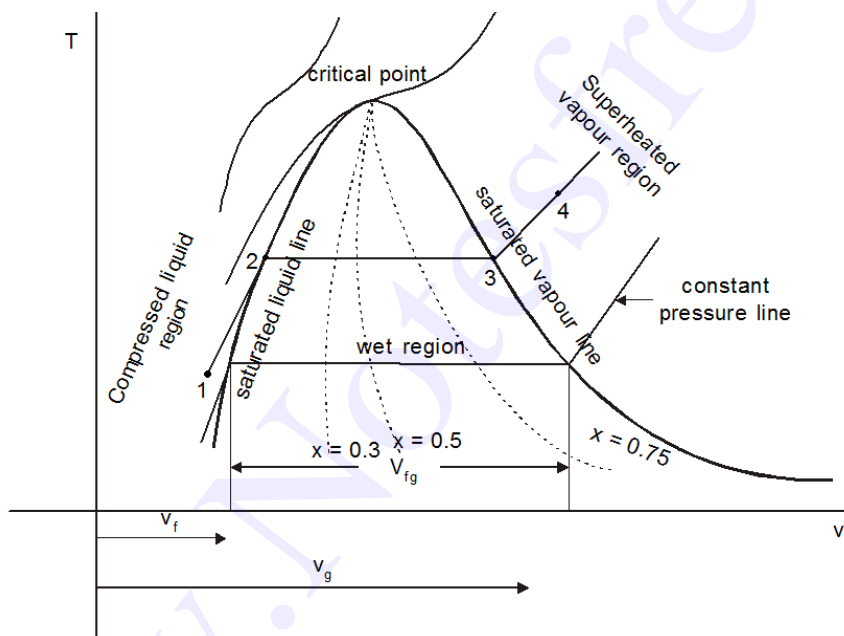

In the *compressed liquid region*, specific volume may be regarded as a function of temperature alone since the liquid is incompressible.

$$v \cong v_f @ \text{ the given temperature.}$$

In the *superheated region*, v is function of both temperature and pressure.

7.5 T-s Diagram for a Pure Substance

Similar to T-v diagram, T-s diagram can also be drawn for a pure substance. Figure 7.5 shows various regions on a T-s diagram. The salient features of this diagram are :

- Temperature is taken on Y-axis and entropy is taken on X-axis

- There are three distinct regions : to the left of the saturated liquid line is the liquid region, between saturated liquid and saturated vapour line is wet region, and to the right of saturated vapour line is superheated region
- Constant pressure lines coincide with the constant temperature lines in the wet region. These lines become curved in the superheated region
- Slope of the saturated liquid line is less compared to that in T-v diagram.

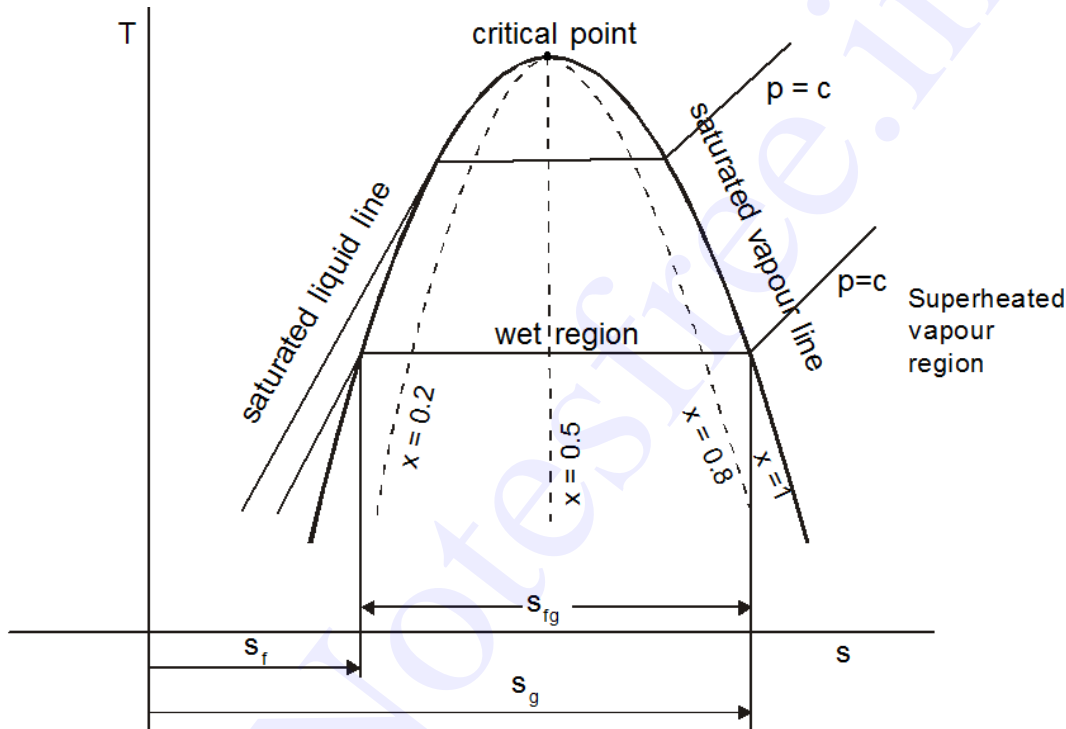

Entropy of a fluid at saturated liquid state $s = s_f$ @ the given p or T

For saturated vapour state

$$s = s_g \text{ @ the given p, T}$$

For Wet state

$$s = s_f + x s_{fg} \quad \dots(7.3)$$

where s_f and s_{fg} are functions of p or T.

For superheated state

$$s = s(p, t)$$

For subcooled liquid

$$s = s_f - c_{pl} \ln \quad \dots(7.4)$$

Where $s_f \rightarrow$ sat. liquid entropy @ the given pressure

- c_{pl} → Liquid specific heat at the given temperature
- T_s → Sat. temp. corresponding to the given pressure
- T → Given Temperature.

7.6 h-s Diagram for a Pure Substance

Within the wet region both isobars and isotherms are the same, but beyond saturated vapour line they deviate. Also it can be noted that the constant pressure lines diverge from each other towards the super heated vapour region. In the super heated vapour region, slope of isotherms become almost zero. The slope of constant pressure curves at any point is a measure of temperature, by noting that .

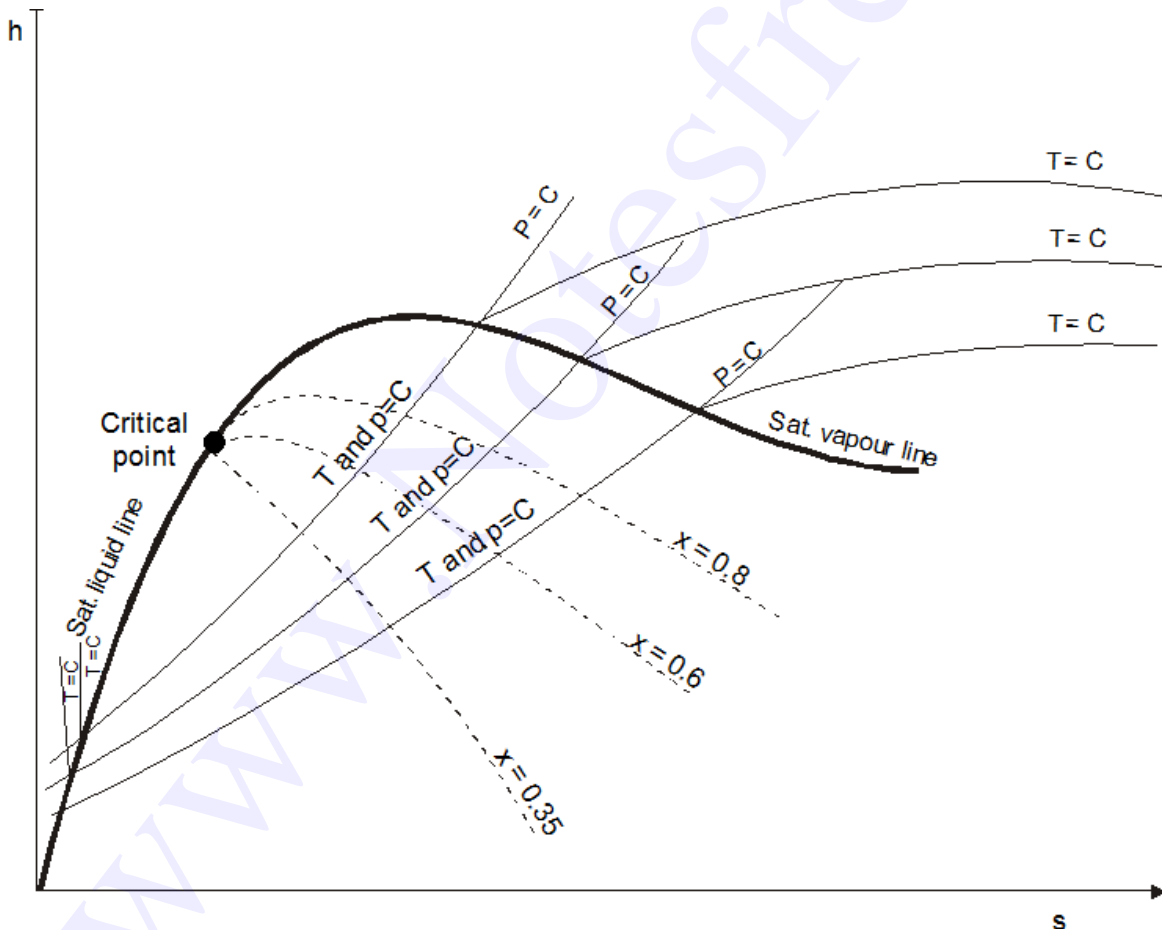

7.7 p-v. Diagram Of A Pure Substance

Figure 7.7 shows the p v diagram of a pure substance. The saturated liquid and saturated-vapour curves meet at the critical point. The region to the left of the saturated-liquid line is compressed liquid, and the region to the right of the saturated-vapour line is superheated vapour. In between the two lines is the two-phase liquid-vapour region. Several isotherms are shown in the figure. The critical isotherm has an inflection point and a zero slope at the critical point. Isotherms below the critical point experience two discontinuities in slope as they cross the saturated-liquid and saturated-vapour lines. In between these two lines, the slope of the isotherms is zero, and a state in this region can be entirely saturated liquid, entirely saturated vapour, or a combination of the two.

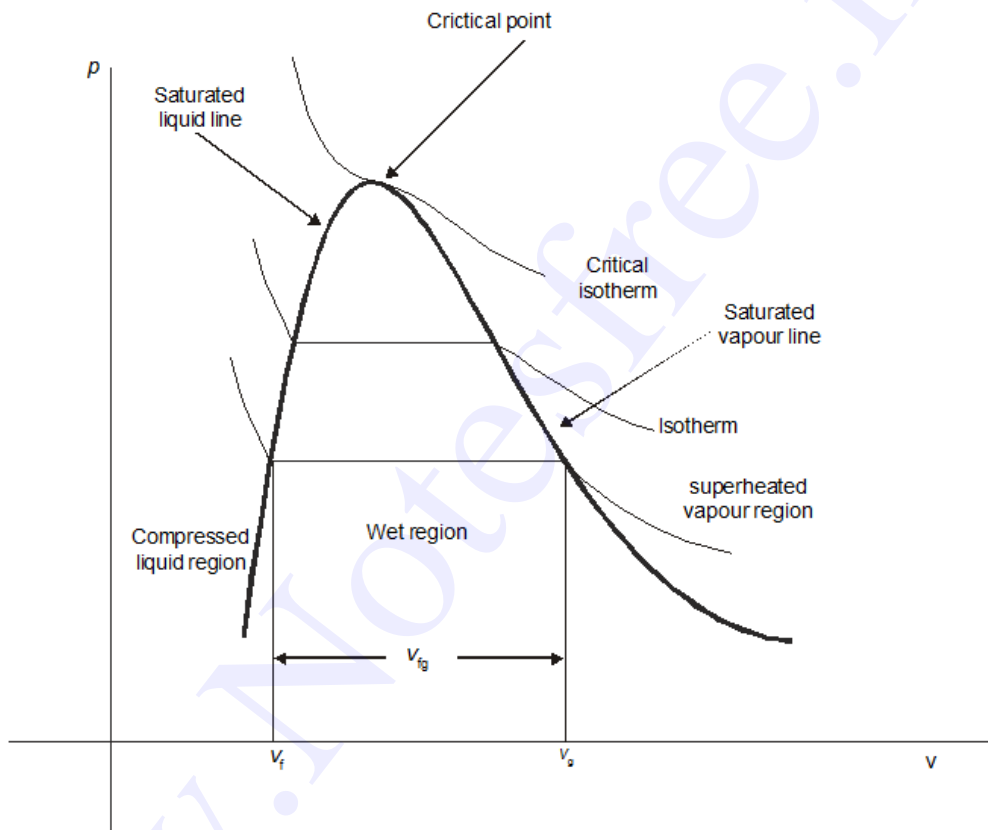

7.8 Extending p - v Diagram for a Pure Substance to Solid Phase

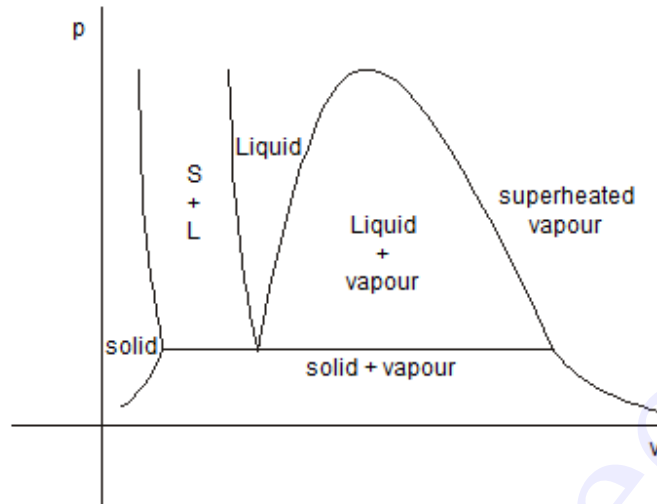

Fig 7.8(a) p-v Diagram of any pure substance (other than water) with an increase in volume on melting

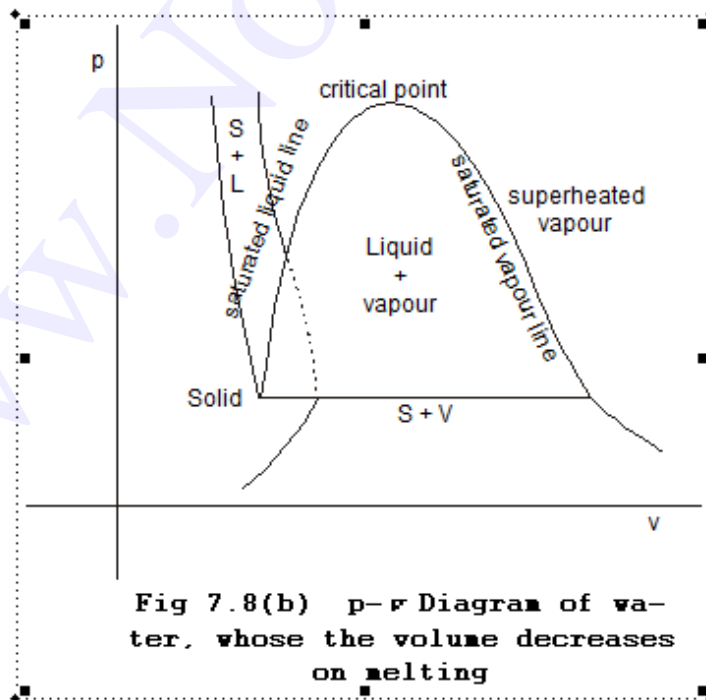

Fig 7.8(b) p-v Diagram of water, whose the volume decreases on melting

Figure 7.8a. shows various regions of a pure substances on a $p-v$ coordinates. Volume continuously increases from solid to super heated vapour region. But for water volume decreases on melting and afterwards increases as shown Figure 7.8b.

7.9 $p-V-T$ Surface

$p-V-T$ behaviour of a pure substance can be expressed in a single three dimensional $p-v-t$ surface as shown in the Figure 7.9(a). For water as its volume decreases on melting unlike other substances its $p-v-t$ surface will be different from that of others as given in Figure 7.9(b).

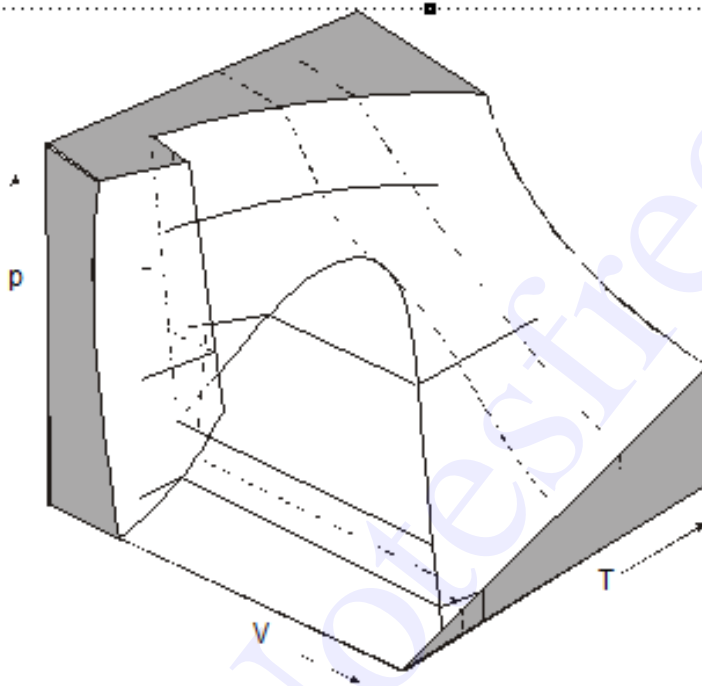

Fig 7.9.a $p-V-T$ surface for a substance that expands on freezing

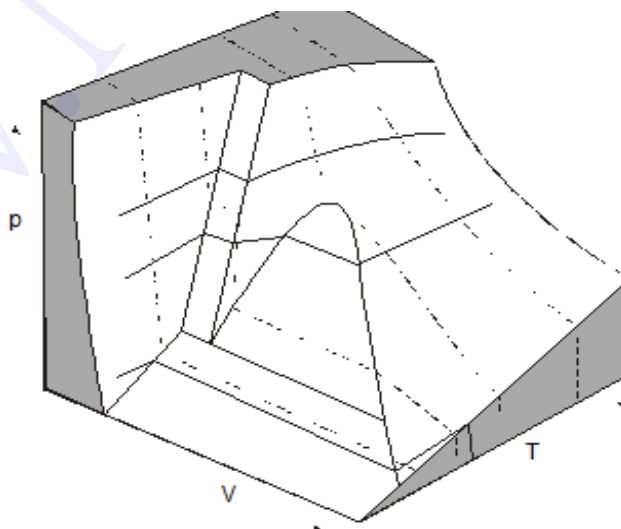

Fig 7.9.b $p-V-T$ surface for a substance that contracts on freezing

7.10 Measurements of Dryness Fraction of Wet Steam

Dryness fraction of wet steam, representing the fraction of steam in the mixture of water and steam can be measured by using (i) Throttling calorimeter and (ii) Separating and Throttling calorimeter. Principle and working of these two devices are presented in this section.

(i) Throttling calorimeter

Let us consider a wet steam as represented by state 1 in the h-s diagram as given in Figure 7.10. When it undergoes a throttling process to state 2, it enters into the superheated region. By measuring the temperature and pressure after throttling the specific enthalpy can be obtained. As mentioned earlier during throttling enthalpy remains constant. Therefore the initial state can be completely fixed since the pressure before throttling and the corresponding specific enthalpy are known. That is,

$$h_1 = h_{f1} + x_1 h_{fg1} = h_2 \quad \dots(7.5)$$

where $h_2 = f(t_2, p_2)$

$$h_{f1} = h_f @ p_1$$

$$h_{fg1} = h_{fg} @ p_1$$

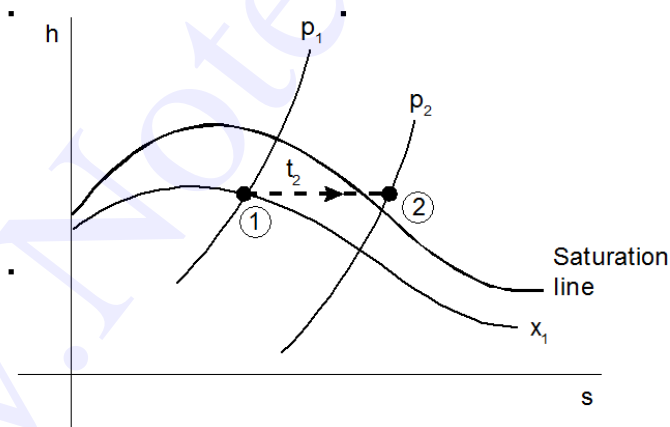

Figure 7.10 Throttling of Wet steam

Schematic arrangement of a throttling calorimeter is given in Figure 7.11. Steam from the main is extracted through a perforated tube projecting into it as shown in the Figure. Pressure of the steam is measured. It is then throttled into a chamber where the necessary pressure and temperature measurements are made. From the chamber the expanded steam is then condensed by circulating cooling water and discharged.

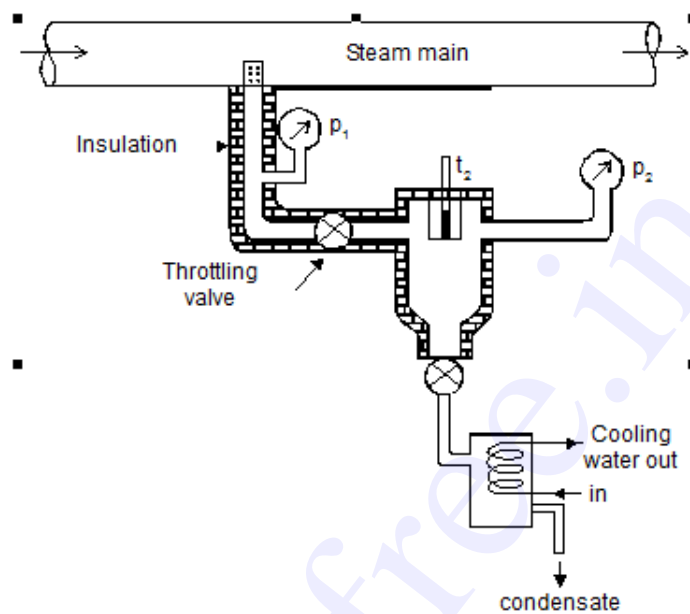

Figure 7.11 Throttling calorimeter

(ii) Separating and Throttling calorimeter

When the dryness fraction of the steam is very low, it becomes superheated vapour only at very low end pressure on throttling. In general, the pressure after throttling for dryness fraction measurement is preferred to be above atmospheric. In such applications, separating and throttling calorimeters are used for dryness fraction measurement.

Wet steam, when subjected to sudden change in the direction of flow, a portion of the liquid falls due to gravity and gets separated from the main stream. Thus the remaining steam becomes rich in vapour, which upon throttling will become superheated vapour even at a pressure higher than atmospheric pressure. This principle is employed in the separating and throttling calorimeter.

The schematic arrangement of a separating and throttling calorimeter is shown in Figure 7.13. The wet steam from the steam main is extracted through a perforated tube and sent to the separator where a portion of the liquid is separated due to sudden change in the direction as explained above. The remaining steam is throttled into a chamber where the required pressure and temperature measurements are made. Mass flow rate of liquid separated in the separator is collected and measured. Mass of the remaining steam is also measured by condensing the throttled steam and collecting it. Let m_1 be the mass of liquid separated in the separator and m_2 be the mass of steam throttled. The state of steam before entering the separator is denoted as state 1 and states before and after throttling are respectively represented as state 2 and state 3.

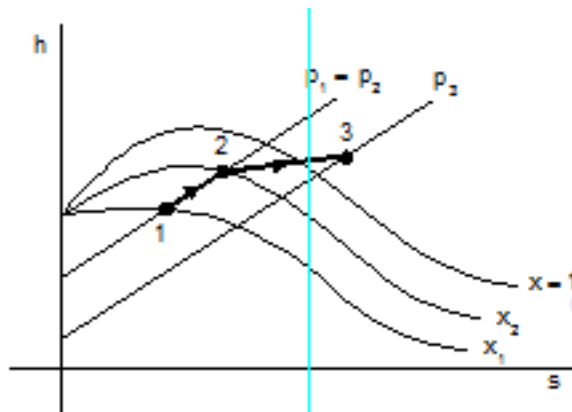

Figure 7.12 Representation of separation of liquid and throttling of steam on h-s diagram

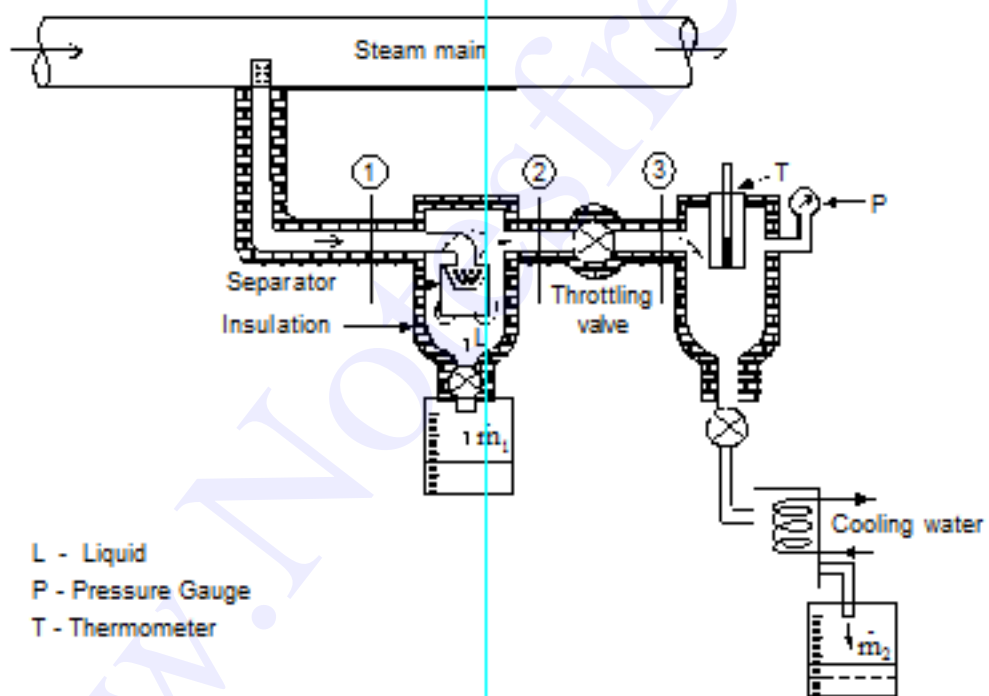

Figure 7.13 Separating and Throttling calorimeter

As throttling is a constant enthalpy process

$$h_2 = h_3$$

...(7.6)

where $h_3 = f(T_3, p_3)$; Since pressure and temperature after throttling are known, from the superheated steam table, h_3 can be obtained.

These two values can be obtained from the saturated table

Therefore x_2 can be computed from equation (7.6).

It has already been mentioned that only liquid is being separated from the wet steam when it is passed through the separator. Then the mass of dry vapour leaving the separator must be equal to the mass of dry vapour entering the separator.

That is

$$(m_1 + m_2) x_1 = m_2 x_2$$

Upon rearranging the equation

...(7.7)

7.11 Steam Tables

As defined earlier to define the thermodynamic state of a given substance, any two independent intensive properties are sufficient. Once the state is fixed, all other properties can be computed. Tables giving the property values of saturated liquid and saturated vapour with respect to temperature and pressure are available along with the properties of superheated steam. These tables can be made use of in the calculation of properties at any state. [See Appendix A1 & A2]

For refrigeration application, fluids like Ammonia and R134a are used. Properties of these fluids are also available in the form of tables.